

Model A Flyer

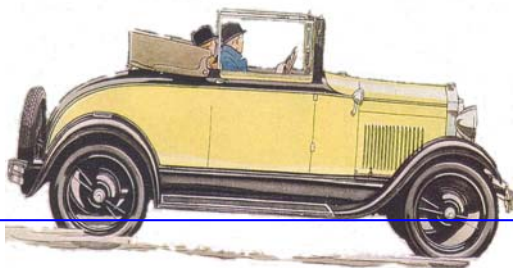

Model A Ford Club of NSW Inc

Web site www.modelafordclubofnsw.com.au

March 2015

Club Meetings are held at Holroyd Community Centre, Miller St., Merrylands. The parking entrance is in Newman Street. Meetings are held from 8 pm on the second Friday of each month unless otherwise stated.

PRESIDENT'S REPORT

Hello all and welcome to March.

I have noticed that some members have not renewed their membership, if you do not wish to renew then a phone call or email would be appreciated, but it is important to be aware that a car cannot be on conditional club registration if the registered owner is not a financial member of the nominated club. The car is not registered or covered by third party or accident insurance.

We have received invitations to the Model A Ford Club of Victoria's 40th Birthday to be celebrated in Hamilton Victoria on the weekend of 15th - 18th May. An exciting and comprehensive program of events has been organised to celebrate this momentous occasion and costs have been well contained. Although the official RSVP has passed I encourage any one who is able to, to attend.

A decision made at the last National meet to abandon concours Judging at future National Meets has been raised by the clubs of Victoria and Canberra seeing it as an injustice to keen enthusiasts who go the extra distance to maintain originality and integrity in their restorations. While it is highly important to encourage and reward these high standards I can well understand the frustration for rally organisers when no cars turn up for judging. I personally feel that no Rally Host club should be denied the right to include concourse judging should they so choose.

The Wednesday Wanderers' outing to Chris's private collection in the Razorback area was like wandering in to an Aladdin's Cave of automotive treasures ranging from a Morris Minor and an early Datsun to American Bling Monster tanks with many hundreds of horsepower, it was so breathtaking that I almost needed oxygen.



Thanks Harry and Laurel for introducing us to your special friends.

Valley Heights Locomotive Museum I found interesting and exciting again. To see two old men manually manoeuvring a steam engine and carriage on the turntable, unlike Archimedes they didn't even need a big lever. Excellent musical entertainment provided by a local Jazz group and light rail tram rides provided nostalgia for the old and excitement for the young. In spite of the rain about half a dozen model A's turned up including new member Charlie Sharpe in his newly acquired Town Sedan backed up by his son in a support vehicle - a Model T Ford.

Finally a reminder to book your accommodation for the Hill End excursion on the weekend of the 2nd and 3rd May, another Rob Taylor extravaganza.

Cheers
Tom Virgona

Upcoming Model A Runs

Model A Run - Sunday 29th Mar - Vintage Car Display Cronulla Good cause fundraiser, so be there!!!!

Ken Warburton is organising a Vintage Car Display in Cronulla's main strip on Sunday 29th March.

This is a fund raising event sponsored by Cronulla Rotary Club to raise money for the disabled.

Not only will there be lots of vintage cars on display, there will also be many ways to spend your money, all for a good cause. Ken would really love to see a good turn out of Model A Fords, as this is his club, but he will be getting many other car clubs from in Sydney to

attend.

So please put this day in your calendar: 7-8am cars arrive - 4pm departure for the vehicle static display.



ar-

Northern A Run Sunday 22nd March

March Run March 22 "Meet the Sponsor"

Assemble at the Tuggerah Supercentre at 10.00 am for a 10.30 am departure.

We will be off on a sightseeing run, a complimentary BBQ lunch & more.

Watch your mailbox and your inbox.

Safe Motoring,
Bob (From Ian Brown)

Maintenance Day Saturday 11th April- Peter Dean's Garage

Saturday 12 midday 11th April at Peter Deans Garage, Unit 12, 3-11 Flora Street, Kirrawee.

Craig Finney is now officially running all future Maintenance Days, Neville has passed the banner on, with all the cut-aways.

Craig will put on a sausage sizzle and drink for \$5pp.

So call Craig if you are going so he can organise the catering on 9548-2424 0438-881-417



Sunday 19th April Run to Berrima to meet Canberra Model A Club

Sunday 19th April enjoy a wonderful drive down to Berrima to meet our Canberra Cousins.

At this stage it is intend to rendezvous at 9:30am at Pheasants Nest, then run as a group into Berrima.

Bring your tables and chairs, a picnic lunch (or buy something there) and enjoy pleasant

surroundings and good company.

More details next newsletter.



Weekend Away to Hill End - 1st to 4th May

Dates: Friday 1st May to Monday 4th May. The main event for the weekend is the historic houses tour on Sunday. So members may wish to either travel up Saturday and return Monday, or leave on Friday and return Monday. Up to you??

Where: Hill End NSW

Accommodation: Hill End Lodge, 3538 Hill End Road, Hill End Ph: 6337 8200 talk to John Carter to reserve your room, please state you are from the Model A Club as I have reserved 10 rooms. For more info go to <http://hillendlodge.com.au/content/RoomsPhotos.aspx#>

Accommodation Cost: Ensuite room with Queen Bed \$110 per night for two nights including Continental Breakfast & the third night is \$90. Cars can be parked next to accommodation bungalows.

Evening Meals: Those travelling up Friday can have dinner at the motel or walk down to the pub for a change of scenery.

Saturday Night in dining room fixed menu = 2 courses \$32pp or 3 courses \$40pp fully licensed.

Sunday Night BBQ night in main dining room is \$32pp. I have indicated we will have dinner on both of these nights.

Saturday Run: For those who drive up Friday a suggested run for Saturday is to The Turon Technology Museum Sofala. Displays engines from 1850 - 1950 in 7 buildings.

Sunday Historic Houses Tour: this occurs only twice a year & Sunday 3rd May is the first tour for the year of six properties. Cost is \$25pp or \$18 concession. I have a hold on 20 places for this tour, payment on the morning of the tour.. See <http://www.hillend.org/open-day/>

Invitation Run - Mothers Day - May 10th Belgenny Farm @ Camden

Interested club members have been invited to show their cars at the Belgenny Farm Mothers Day Event on Sunday 10th May from 10am - 4pm.

Entry fee of for each Model A and occupants is FREE, otherwise it is \$5pp & children under 12 free. There will be historical tour of the farm, working dog

shows, sheep shearing demonstrations, cow milking and butter making as well as a snake and reptile show. Sounds like a really good value day for a Mothers Day outing.

There will also be stalls, pony rides, steam museum, puppets and much more....

Young Cherry Country Model A Rally please note date change, now 4th - 7th September "Book Now"



Model A club members and their friends are invited to take part in the Young Cherry Country Model A Rally to be held from the 4th - 7th September 15.

The Rally:

Date: Fri 4th - Mon 7th September

Friday 4th: Y.H.M.C. Club House . Arrival, Registration and afternoon Tea -

Saturday 5th: The first of the two major runs.

Sunday 6th: Run #2.

Sunday evening dinner at the "yet to be decided"

Monday 7th: Aussie BBQ breakfast at "Lambing Flat Chinese Tribute Gardens" before departing

for home.

Accommodation: Young Services Club which has excellent facilities for the Dinner as well as motel accommodation (The Federation).

PLEASE EMAIL Barry if you intend coming along to assist the boys with planning... Thanks
barry-rose@netspace.net.au

Kind Regards

Col Harmer Mob 0419822975

Barry Rose Mob 0409490223

Northern A Run - 19th July to visit "The Garland Collection"

The Northern A's are running to Steve & Meagan Garlands home in Butterwick. Steve has a wonderful collection of Model As and Model Ts in two purpose built sheds. You will also see his restoration area, sand blasting area and paint room. This is a real treat, and you will be amazed at what this man can do....



HARS Albion Park Run Report

Another well attended run, 35 members and guests and 8 Model As with many moderns.

Weather at Albion Park was fine and windy, We had a comfortable seating area, and everyone enjoyed the many and various aircraft displays.



National Concourse Judge Wanted

The Model A Ford Clubs of Australia are looking to set up a National Concourse Judging Committee. It is intended that this committee comes together at each national meet to judge any concourse entries. The aim of the committee is to provide consistency of judging, and take the burden off the host club in concourse judging.

If you would like to be considered to become a concourse judge, please let Tom Virgona know, on 9809 6350.

You do not need previous experience, just a desire to learn and become a part of the judging team.

Market Place

For Sale: Model A engine for sale \$150 negotiable. Roslyn Windwood 6581 0846.

For Sale: Full set of 1931 Steel Mudguards \$ 880. V/good condition, 4 x 1930 wheel rims \$ 160. **call Craig Finney 9548-2424 0438-881-417**

Wanted: Right Hand Drive Bell housing, 27 Steering Box, Spark & Throttle rods, Starter pedal and swivel, foot brake cross shaft, **call Ron Cox 9743 5955**

Services: Model A Ford White Metal Bearings - if needed **call Dean, Dean Repairs on 0418 680 027**

The Wednesday Wanderers

4th March Wanderers Outing Report

Morning tea at Curry Reserve before driving in convoy to the parking area on Razorback. Harry and Laurel met us there making up 25 Wanderers going out for a Summers day run.

Off to a private car collection owned by Chris Manion who gave us the grand tour. What a magnificent collection, from an FX Holden to a late model Mustang. My pick was the beautifully

restored 58 Chev, but I'm sure each of us would have their favourite.

Drove through the green countryside to an impressive new suburb, Bingara Gorge near Wilton. We had a tasty lunch in pleasant surroundings at the Bingara Gorge Cafe.

Great to see Trevor and Pat in their trusty 'A' braving the peak hour traffic from Pennant Hills. Also welcome back members Ron & Edna Cox driving their Morris Minor.

Thanks Harry and Laurel for showing us the car collection and this new suburb.

Joan Bailey

Wednesday Wanderers 1st April to the NSW Art Gallery

Meet 9-30am at Gateway Complex, opposite Quay next to Maccas for coffee & cake. Then by bus up George Street alighting outside the QVB, where will cross the road to York St to connect with the 441 Bus to The Gallery. After viewing we will have lunch in the Gallery Cafe.

For more details contact John Hyland 46571734.



February Run Reports

Northern A Run to Kariong Gardens & Japanese Gardens. Ten hardy souls in 5 model A's turned up on a wet Sunday morning at Ourimbah. We then proceeded to the Kariong Gardens at Mt Penang but due to the weather it was closed. Not to be perturbed, we gathered for lunch, the weather cleared however the gardens remained closed.

After lunch we proceeded to the Japanese Gardens at East Gosford to enjoy the Kio Ponds, garden and textile art display. Despite the inclement weather an enjoyable day was had by all.

Sydney Run to Valley Heights Steam Museum. The rain also played a significant role in this Model A outing. The museum had gone to a lot of trouble to put on a some great displays & a Jazz band. But due to the weather the only people there were the Model A Fords and the Model T Fords with their drivers and hardy passengers. Trevor Davis also received the best period Dress Award.



Your 2015 Committee

President	Tom Virgona	02 9809-6350 or 0420-342-392
Vice Pres	Peter Wiggzell	02 9837-2490 or 0419 259 056
Secretary/Club Reg	Rob Taylor	02 9411 5644 or 0417 861 411
Treasurer	Trevor Davis	02 9484-5116 or 0400-285-088
Public Officer	John Hyland	02 4657 1734
Committee Members	Ken Young	02 4677-2446 or 0428-697-717
	Jim Haling	02 9498-5038 or 0431 904 311

Ford Delegates

Phil Dalton 02 4659 6075 or 0481 348 295
Ron Elks 02 9644-9059 or 0419-296-201

CMC Delegates

Ron Elks 02 9644-9059 or 0419-296-201
Phil Dalton 02 4659 6075 or 0481 348 295

Memberships

Peter Wiggzell 02 9837-2490 or 0419 259 056

Librarian

Jim Allingham 02 9522 6094 or 0418 674 059

Editor

Rob Taylor 02 9411 5644 or 0417 861 411

Wanders co-ord

John Hyland 02 4657 1734

Editors email: thetaylors79@bigpond.com

FLYING "I" R.I.P.

Over the years in this column I have mentioned the name Dan landola in relation to Model A four bangers and lakes racing so it will be familiar to many regular readers.

Some will know the name from "The George Riley Scrapbook" that he authored or from the notation inside the cover of Riley's "How to Build a 100 MPH Model A" and California Bill's "FOUR BARREL MANUAL" booklets he re-produced during the '90s. He was also involved in establishing the Secrets of Speed Society (SoSS) and the Ford A Speed Technology (F.A.S.T.) groups and writing for their magazines.

Dan became a mentor of mine as soon as I read his article titled "GETTING MORE FROM YOUR 4" published in the May 1970 edition of the USA magazine, Rod & Custom. Little did he or I know then that in 1986 we would meet, become mates, and spend many good times at the Bonneville and El Mirage dry lakes together as well as time in his workshop preparing his Lakester for the meets.

Alas such times will never be repeated for Daniel Richard landola passed away on the 24th of March this year after a bout of ill health. His 82 years were well spent and his legacy will live on in his writings as well as via the aluminium T and A Model speed parts he made under the Flying "I" banner. His surname is pronounced eye-an-dola hence the Flying "I". If you knew Dan then you also know of his loving wife Deanna to whom I have expressed condolences on behalf of readers and myself. Space is limited in this month's column but I will expand further on his Flying "I" efforts to make early Fords fly in a future issue. ■

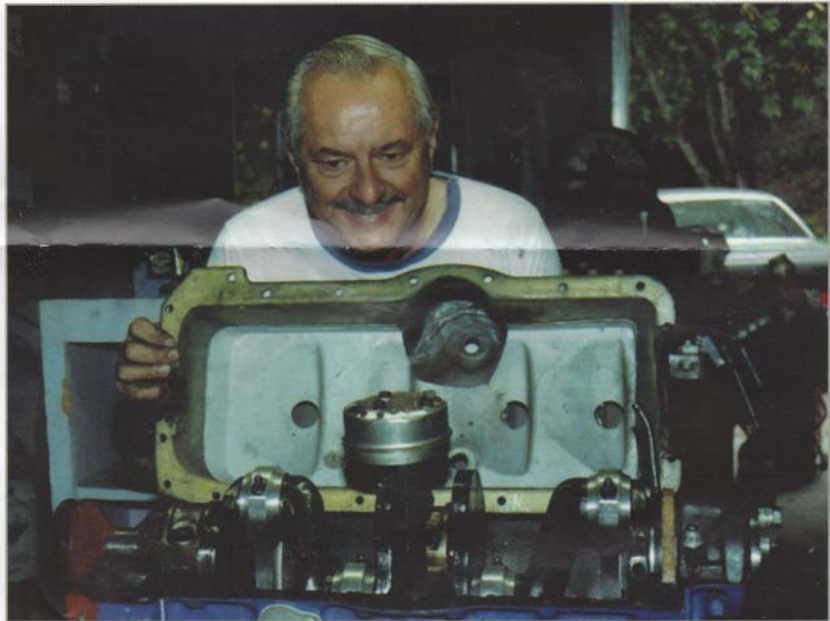

Dan landola proud as punch about to install the oil pan on his Model A fourbanger engine we assembled prior to racing at Bonneville in 1993. Apart from the "B" counterweighted crankshaft, bronze #1 and #2 main bearing caps and V8 oil pump, Dan had finally realised a dream of running his own design aluminium connecting rods and pistons in his fuel injected Jenkins headed four banger. More on the engine in a future issue.

Constantly Leaking Carburettor

I have been putting up with a leaking carburettor for the past year now, and it was really bugging me. I asked lots of questions and have read many books on the subject, but nothing would fix it. I bit the bullet and pulled the carbie down for the umpteenth time and tried something different. Keeping in mind it has a new needle and seat, gasket set, float height checked etc. After removing the top the top of the carbie, I dried out the float bowl & needle areas with compressed air. I then gradually filled the float bowl reservoir with petrol until I could just see the fuel in the cap and main jets (not overflowing).

I waited awhile, then noticed the fuel starting to seep around the area where the cap jet shaft fits into the screw base. I could not believe it, there it was, a hole in the cap jet. I removed it and soldered up the area indicated in the picture. Reas-

sembled and fitted the carbie back on the car and left it till next morning full of fuel. Next morning "no fuel leak".. I am very happy with my fix and hope it helps you.. Regards Peter Butler.

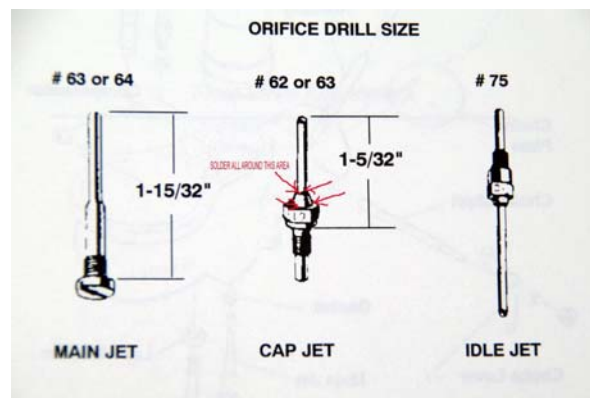

CLUB RENEWAL Please note, there are 22 members who have not yet renewed their 2015 membership. If your car is on historic registration with our club, it is now unregistered and un-insured, as you must have current membership. A reminder note will be sent shortly, please renew promptly or let us know if you are not renewing...thanks