Model A Flyer



Model A Ford Club of NSW Inc

Web site www.modelafordclubofnsw.com.au

OCTOBER 2012

Club Meetings are held at Holroyd Community Centre, Miller St Merrylands. The parking entrance is in Newman Street. Meetings are held from 8 pm on the second Friday of each month unless otherwise stated.

PRESIDENT'S REPORT

I'll begin my report with a close encounter of the Very Hot Side. You will have seen the news recently of the fires which raged out of control on the Central Coast. If you watched the 7 news you would have seen the cameras inside a house looking out at the fires. That was club member Richard & Beth Payne's home, at Pretty Beach. Also Alan & Rhonda Hale from Wyee were in Canberra while the flames were burning at the end of their street. Thank god all turned out OK. On the sick and recovery trail we have Ron Huckstepp, Marie Hyland and poor old Jim Allingham who just can't take a trick. To all of you and to any other members who may be not travelling to well, we wish you well, and a speedy recovery.



"Hey Ron, did you see the Paddington Bare"

This month's Wednesday run to Paddington was again well attended. Just to see what they have done with the old water storage tank was amazing. The locals in the street were nice too!. The shops ca-

tered for "special clients". Trevor couldn't resist taking a photo of a shop dummy clad in this beautiful red underwear. Thank god the battery in his camera was charged because the one in his pacemaker was going flat very quickly. He looked at Pat and she just shook her head, action speaks louder than words. It was now time for the 19 starving to hit the Pub for lunch. Thanks to Ron Doyle for a good day.

The Lugarno Fair / Presidents Run was another good day out, it was hot, many would have killed for a large umbrella. The Allinghams took home a trophy for the most unusual car on display with their Taxi Tudor. While a couple of days later the First Lady Nola finds out she had won a digital movie camera. With 18 booked in for the Katoomba event and about 30 plus for the Hunter Weekend sure looks well for these two outings.

Ken Warburton has been looking into the possible hire of a large multiple car trailer to transport the model A's to Perth for the National Meet in 2014, please give him a call if you are interested. 0438 692 737. Yes, the AGM is next month, please consider taking on a position on the committee. Hope to see as many members as possible at our November Meeting. Lets see if we can beat the 41 who were at the October Meeting.

As Always, Happy Motoring, Mal.

My Quotes For The Month,

"Well Done Is Better Than Well Said." and

"True Wealth Is What You Are, Not What You Have."

Nomination of Committee Members 2013

*Yes that time is drawing close once again. We have our AGM in November, where all club positions are put up to the vote. **The last page of this newsletter** is your chance to nominate yourself, or another member for a position on the*

*committee. This is important, as our club is run by committee, and we require to have an elected committee, otherwise the club ceases. **Please seriously consider becoming a committee member, for the sake of the club..***

Model A Shock Absorbers - Part 1.

This article is intended as a guide for those who want to restore and install original Model A shock absorbers. If intending to enter a vehicle for National Model A Meet concourse judging then original shock absorbers are essential. However if the vehicle is not required to be original in every respect then installation of reproduction shock absorbers could be the easiest solution although somewhat expensive.

Part 1 of this article covers the following topics:

- Source of restoration information.
- What the shock absorber is intended to do.
- Taking shock absorbers apart.

Source of Restoration Information.

A reference article for restoring shock absorbers is in the book titled 'How To Restore Your Model A' -Volume 2, pages 40 to 43. The article also refers to other references in very early issues of the MAFCA magazine 'The Restorer'. The primary reason for referring to this article however is that it contains an excellent exploded view of the Houdaille shock absorber. The names given to component parts will be adopted here. However there are a number of matters contained in this reference which are not supported and these will be discussed in due course.

What The Shock Absorber Is Intended To Do.

An understanding of the design principle is important as the shock absorber is an integral part of the suspension system. When a wheel hits a road bump the wheel and axle will move upwards and compress the spring. The extent of the jolt felt depends on the stiffness of the spring and also on the sprung weight of the vehicle compared to the weight of the unsprung weight, the latter being that of the wheels and axle. If the resistance of the shock absorber to movement is very stiff this will also serve to transmit the jolt. To alleviate this problem the shock absorber as fitted to the Model A is designed for relatively easy movement on the upstroke of the lever arm. If shock absorbers were not fitted the

stored energy in the compressed spring will then be released causing the wheels to strike the ground with considerable force. As this force will be felt within the vehicle the purpose of the shock absorbers is also to slow down this release of energy. Hence the Model A shock absorber is designed with two features, a low resistance to upwards motion of the shock lever and a greater resistance to downwards motion of the shock lever. If the spring is very stiff due to lack of lubrication then the shock absorbers become ineffective. The spring therefore is also an integral part of the suspension system and requires maintenance.

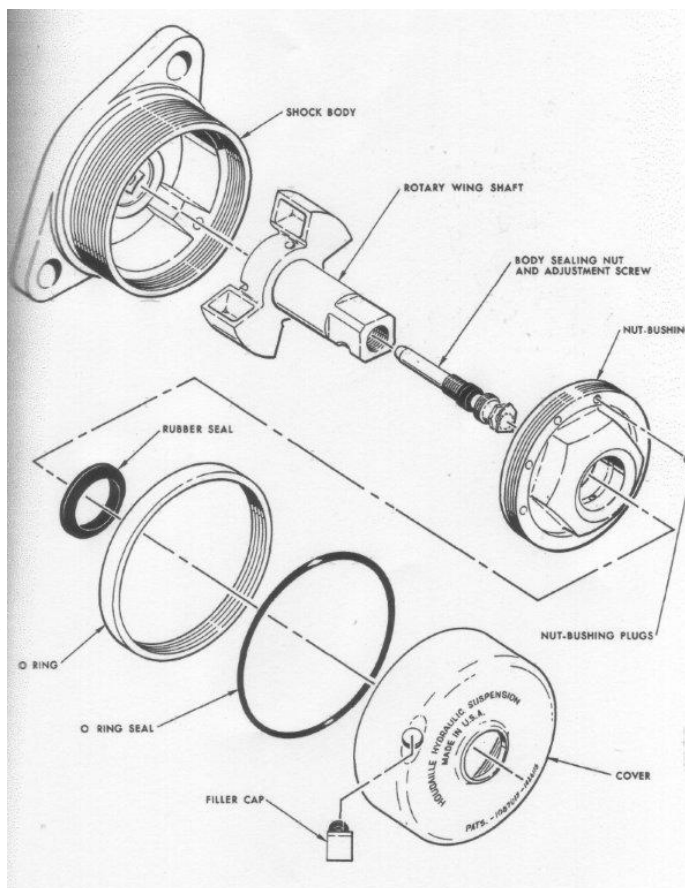

Taking Shock Absorbers Apart.

Due to corrosion this is the most difficult part of the restoration. As stated in the reference article, after loosening the retaining ring the outer chamber cover might be unscrewed, otherwise it will respond to moderate heat followed by gentle tapping around the edge. Use of a chain wrench might also prevent distortion of the cover. The application of wax to the heated edge of the cover may also assist due to capillary action.

Separation of the inner flange (ie nut bushing) from the outer case (ie shock body) however may in the extreme case require access to a lamp post plus a massive lever

fitted to a robust spanner. Another method worth trying is prolonged soaking in a penetrating fluid such as kerosene or carburettor cleaner. Placing the shock absorber upright on a hot barbecue so that the outer case expands faster than the inner flange may also loosen the thread. **Important:** Do not drive the air vent plugs (ie nut-bushing plugs) in as stated in the reference as this may cause damage. The plugs are not intended to secure the inner flange in place as stated but rather to vent trapped air from within the shock absorber.

To be continued: In following issues there will be additional restoration information and advice on restoring check valves, type of filling oil required and the testing and adjustment of shock absorbers.

Wednesday Wanderer's Events

Wanderers Visit to Paddington in October

19 Wanderers enjoyed a great day wandering around historic Paddington. We started at the Secret Gardens of the historic Water Reservoir opposite Paddington Town Hall.



From there we explored the interesting shops of Paddo's side streets - exclusive boutiques in delightful terraces.



When lunch time appeared we nipped into a lovely pub for a great pub lunch.



Thanks again Ron for organising another fantastic outing.. Barb Bosher

Join the Wanderers at their next outing

Tuesday 6th – Thursday 8th November, 2012. 3 day/ 2 night Katoomba Visit.
Booked out.

Wednesday 5th December - Xmas lunch Drummoyne Sailing Club.
Meet at 11am for pre lunch nibbles & natter. Enquiries Tom Virgona 9809 6350



Market Place

For Sale: Model A Engine" Blocks" and Component Parts, Build an Engine IKEA style, sort of Flat pack. Call Mal Bradley. 95226614 or 0431 764 103.

For Sale: 2000 Jayco Westport 22ft Caravan with awning and complete annexe, split air conditioner, trunk across back of van. Set up for around Australia. Many extras. Price **\$38,000.00 ONO** phone Neville Jones 029639-7044, Mob 0428293301.

For Sale: Two Ford Motors partly dismantled \$150. Call John Everett 0297734941 mob 0408852878

For Sale: Spartan Model A Rebuilt 6V Horn \$250. Call John Everett 0297734941 mob 0408852878

Please email Editor thetaylors79@bigond.com if you want your listing to stay next issue!!!!

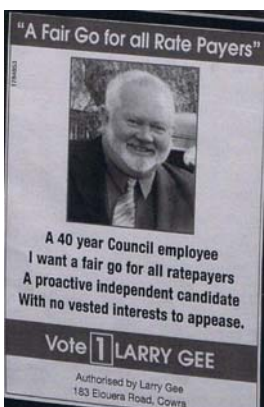

Is our Cowra Country Member, Larry Gee running for President of the Model A Club???

My mistake, he was running for local council.. Not sure whether Larry won the ticket or not, but certainly used his Viccy to good effect in the council election promotion.

VOTE 1 - LARRY GEE



Club Events - Be cool, be there.



21st October Memorial Run Woronora Dam –

Approx 10 mile south of Loftus Tram Museum take the old highway after Waterfall. Meet at lower car park “Gazebo” at 10am, club BBQ supplied. Jim Allingham 9522 6094 or 0418 674059



23-25 November Club Run to Hunter to visit Steve & Meagan Garland at their place at Butterwick, just near Morpeth. They have two large sheds full of Model Ts & As that Steve may one day restore. **Neville Jones is joining us to present another Maintenance Seminar for our country members too.** So far I know of 30 people coming, so please let me know if you are...Rob Taylor 0417861411

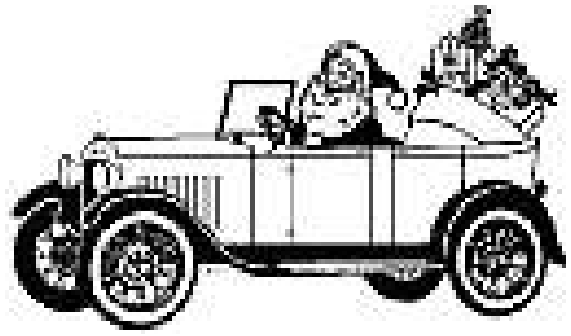

2 December Christmas Picnic Parramatta Park.

Sunday 2nd December 2012. Christmas Picnic at Parramatta Park.

(IMPORTANT – Members bringing their children who are under the age of 12 are requested to contact Trevor Davis no later than the AGM in November so that we can arrange Xmas gift bags. Members bringing grandchildren are requested to bring presents for them.)

Meet from 10 am onwards and bring everything you need including hats, seats, food and drink The main entrance to Parramatta Park is from the corner of Macquarie St and Pitt St. Proceed to the play ground and BBQ area at the northern end of the park. There will be an opportunity for a 15 minute walk to visit the Governor Arthur Phillip camping spot of May 1788 at the junction of the Parramatta River with the Darling Mills and Toongabbie Creeks.

Enquiries Trevor Davis 9484 5116 (M) 0400 285 088.

Invitation Events

Sunday 4th Nov Cruzin For A Cure in aid of Westmead Medical Research Foundation. Cruzin For A Cure will be held on **Sunday 4th November 2012**. The meeting point for the cruise will be 9.30am at University Western Sydney (UWS), Victoria Road, Parramatta for a 10.00am departure.

The cruise will head to Camden Airport where there will be a BBQ, Jumping Castle, Face Painting, Airport Tours, Raffles, Dj and more. Entry will be \$10 per car and will be collected at the gate at Camden Airport. **Contact Steve on 0434 367 224.**

23rd September Lugarno Lions Club Fair & Presidents Run

It was a perfect day for top down touring. At Lugarno we had 7 Model A's, a Mustang & a Corolla. In addition there were over a hundred other assorted cars on display, as well as rides and stalls, a real fair.

It was a fun day out, although we were not prepared for such a sunny hot day.. So who ever had an umbrella, was really popular.

Thanks to all those that attended for supporting the Lions Club, and thanks to the Finn's for organising the day..



Nomination Form for Committee and other Club Elected Positions for 2013.

Note: This form must be returned to the Secretary in time for the October meeting of 12/10/2011 and all nominees must agree to their nomination prior to submitting this form.

POSITION: PRESIDENT
 Name Proposer Secunder

POSITION: VICE PRESIDENT
 Name Proposer Secunder

POSITION: SECRETARY/CLUB REGISTRAR
 Name Proposer Secunder

POSITION: TREASURER
 Name Proposer Secunder

POSITION: PUBLIC OFFICER
 Name Proposer Secunder

POSITION: COMMITTEE MEMBERS (1) and (2)
 Name Proposer Secunder
 Name Proposer Secunder

POSITION: MEMBERSHIP DIRECTOR
 Name Proposer Secunder

POSITION: COMBINED FORD CLUB DELEGATES (1) and (2)
 Name Proposer Secunder
 Name Proposer Secunder

POSITION: C.M.C. DELEGATES (1) and (2)
 Name Proposer Secunder
 Name Proposer Secunder

POSITION: LIBRARIAN
 Name Proposer Secunder

POSITION: WEDNESDAY WANDERER'S CO-ORDINATOR
 Name Proposer Secunder

POSITION: EDITOR
 Name Proposer Secunder

NSW Model A Ford Committee 2012

President	Mal Bradley	02 9522 6614 or 0431 764 103
Vice Pres	Barbara Boshier	02 9871 2030 or 0422 147 264
Secretary	Trevor Davis	02 9484 5116 or 0400 285 088
Treasurer	Jim Haling	02 9498 5038 or 0431 904 311
Public Officer	Marion Cook	02 9724 3914 or 0418 625 158
Committee Members	Norm Boshier &	02 9871 2030 or 0422 147 264
	Tom Virgona	02 9809 6350
Ford Delegates	Phil Dalton	02 4659 6075 or 0400 195 359
	Ron Doyle	02 9772 3785 or 0412 764 741
CMC Delegates	Ron Doyle	02 9772 3785 or 0412 764 741
	Phil Dalton	02 4659 6075 or 0400 195 359
Memberships	Neville Jones	02 9639 7044 or 0428 293 301
Librarian	Ron Doyle	02 9772 3785 or 0412 764 741
Editor	Rob Taylor	02 9411 5644 or 0417 861 411
Wanders co-ord	Barbara Boshier	02 9871 2030 or 0422 147 264

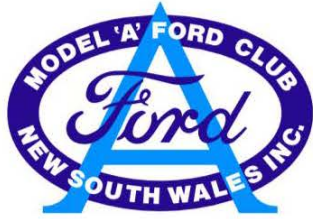

MODEL 'A' Ford CLUB

NEW SOUTH WALES, INC.

P.O. Box 162, PANANIA, 2213.

MEMBERSHIP 2013

RENEWAL OF MEMBERSHIP

Membership fees for 2013 are due on the 9th November, 2012

If you wish to renew your membership please fill in the details below, and return with your remittance to:

Model A Ford Club of NSW, Inc. P.O. Box 162, PANANIA, NSW 2213 or pay at the meeting.

NAME IN FULL

Partner:

Address:

Suburb: Post Code

Postal address (if different to above)

Phone No. Mobile No.

E-mail Address:

Children: Name Date of Birth

Name Date of Birth

Name Date of Birth

Name Date of Birth

Vehicle details Status*

..... Status*

..... Status*

..... Status*

*Original, restored, unrestored, under restoration, etc.

CITY MEMBER - \$45.00

COUNTRY MEMBER - \$35.00

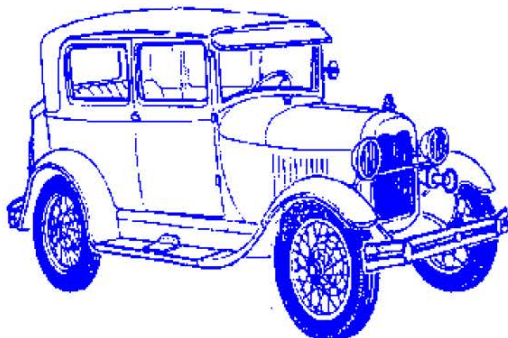

**Membership Fees due
9th November, 2012**

Receipt No

Date Paid.....