

Transmission Overhaul Pictorial August 2018

by Tom Endy

The Model A transmission is not difficult to overhaul. It can be done with simple hand tools. However you do need a shop press to remove and install the front and rear ball bearings. There are some areas that can cause grief unless you are aware of some subtle differences in the evolution of the design. In addition, there are also some parts that can easily be installed incorrectly.

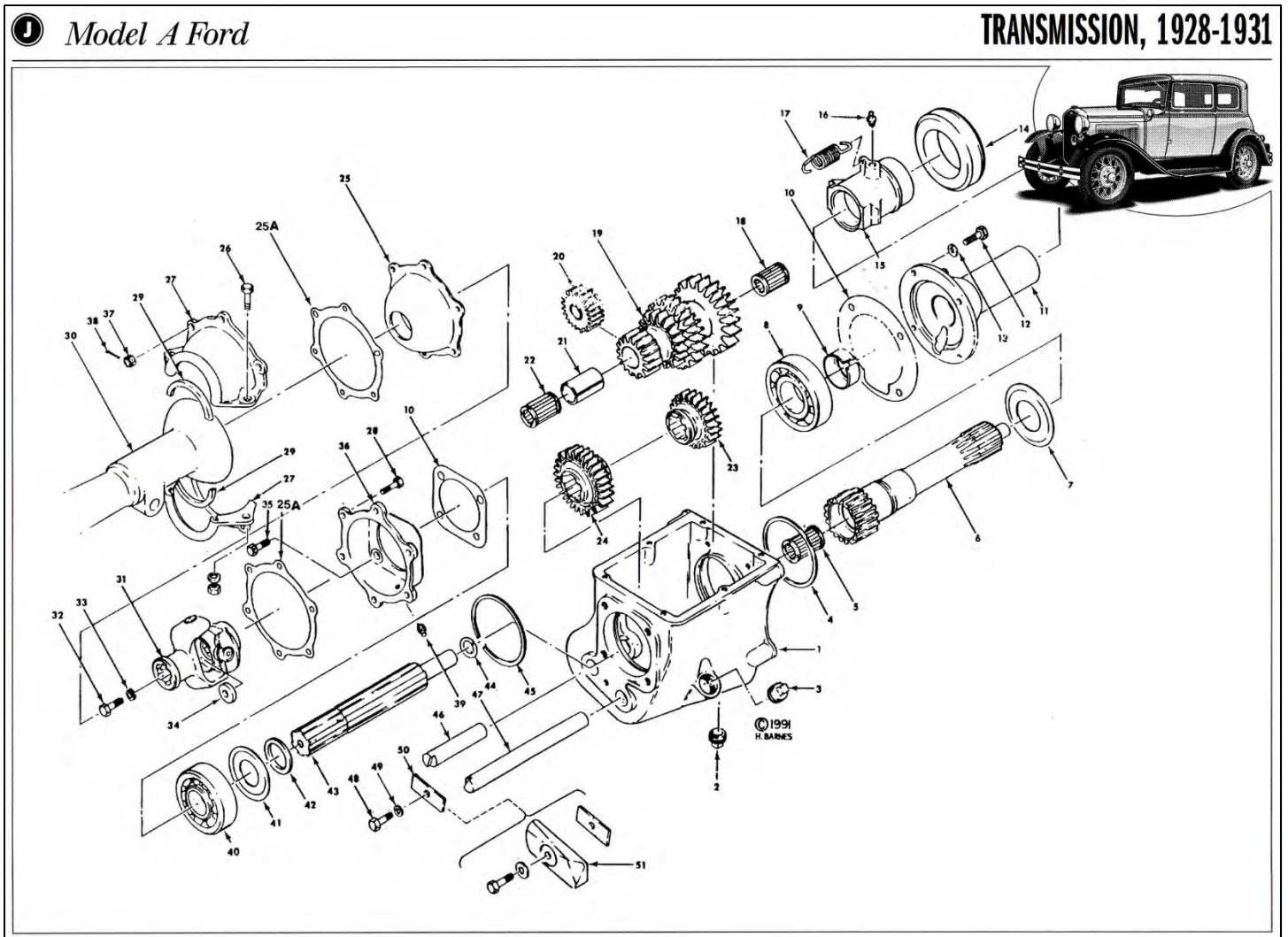

The drawing shown above was done by the late Howard Barnes. Years ago he granted the Victoria Association permission to use this drawing. The drawing depicts a later transmission that uses snap rings in each end of the housing to retain the two ball bearings. The later transmissions also did not have bronze thrust washers at each end of the cluster gear. The later transmission also uses a replaceable front spacer on the main shaft. More important the later transmissions used oil baffles that are slightly larger in diameter. This is an area of grief; if you install the later oil baffles in an early transmission you will jam it up. Suppliers only sell the later oil baffles, so beware.

The bolt pattern on the rear bearing retainer was changed mid-production. All will fit the transmission housings, but not the U-joint coupler, so beware.



Shown here is a complete later transmission ready for assembly including the new parts that I consider 100% replaceable.

100% Replaceable Parts* (Bratton's Antique Auto 2018)

10160 (A7025-LS)	Main drive ball bearing\with seal (1 required).....	\$8.75
10320 (A7065-LS)	Main shaft ball bearing\with seal (1 required).....	\$9.25
10550 (A7118-A)	Roller bearing\short, two required (price for two)	\$12.10
10600 (A7121-A)	Roller bearing\long (1 required).....	\$4.90
10620 (A7140)	Reverse idler shaft\with O-ring mod.....	\$8.50
10480 (A7111)	Cluster shaft\with O-ring mod.....	\$10.95
10210 (A7045-B)	Front bearing spacer & snap ring.....	\$5.50
10680 (A7153)	Gasket set.....	\$3.50
10270 (A7063)	Pilot bearing spacer.....	\$ 0.75
Total.....		\$64.20

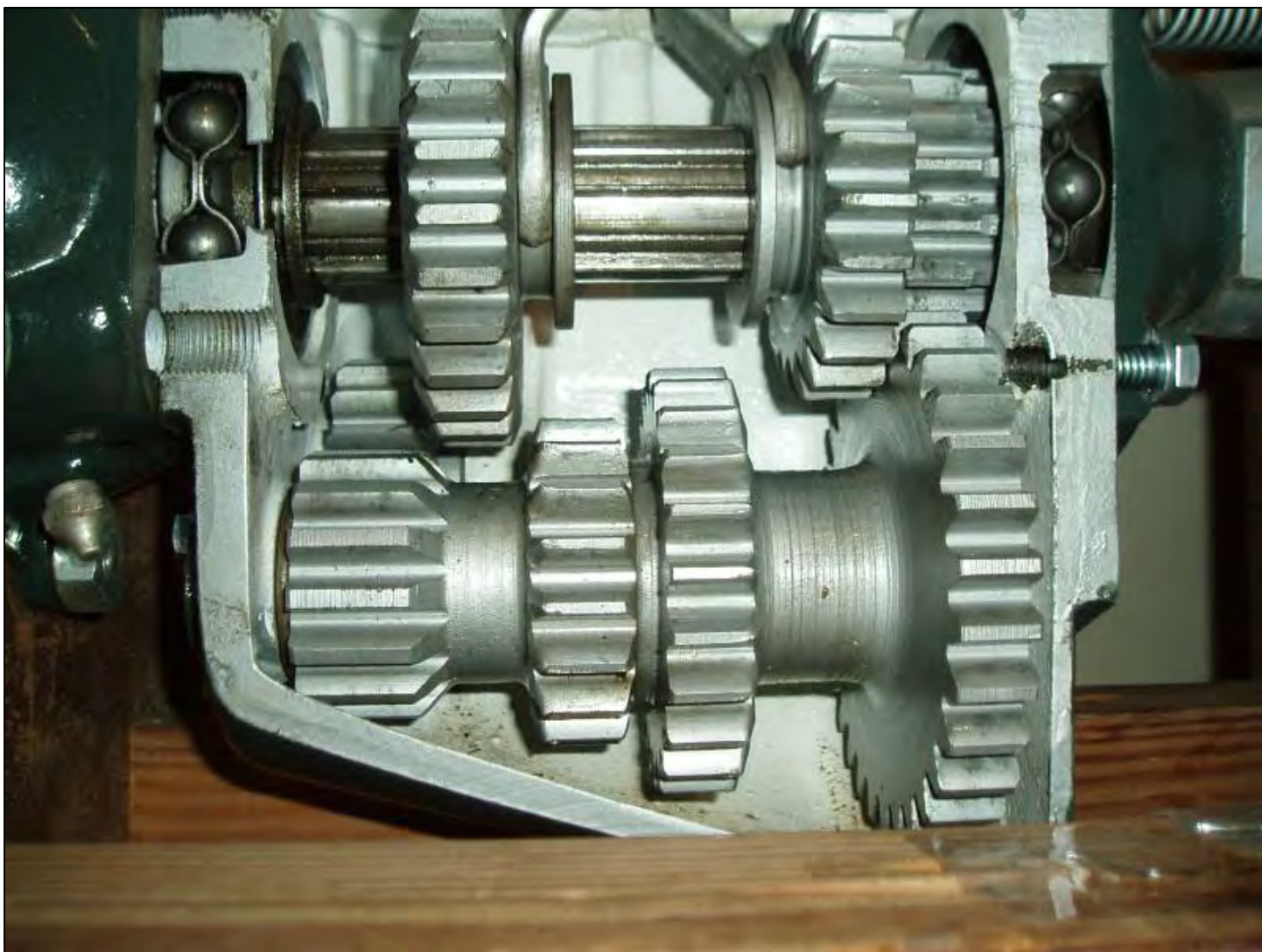

Shown here is a cut-away of a transmission that was on display at a MAFCA meet a number of years ago.

The photo on the next page shows that a Model A transmission is so simple a child can assemble it.





Shown here is the evolution of the transmission housing. On the left is a very early housing that used a large idler gear assembly as can be seen by the large hole on the lower left. The housing also has solid bearing stops integral to the housing.

In the center is a mid-early housing that has solid bearing stops integral to the housing.

On the right is a later housing that uses snap rings in the housing for bearing stops.



Shown here is a repair to a transmission housing that was done years ago during a time when things were repaired instead of replaced.



The transmission pictorial overhaul starts with this photo and will continue until the completion of the project.

This transmission has come into the shop for overhaul. The customer complaint was: “profusely leaking oil”.

This is what they normally look like when removed from a car, extremely cruddy.

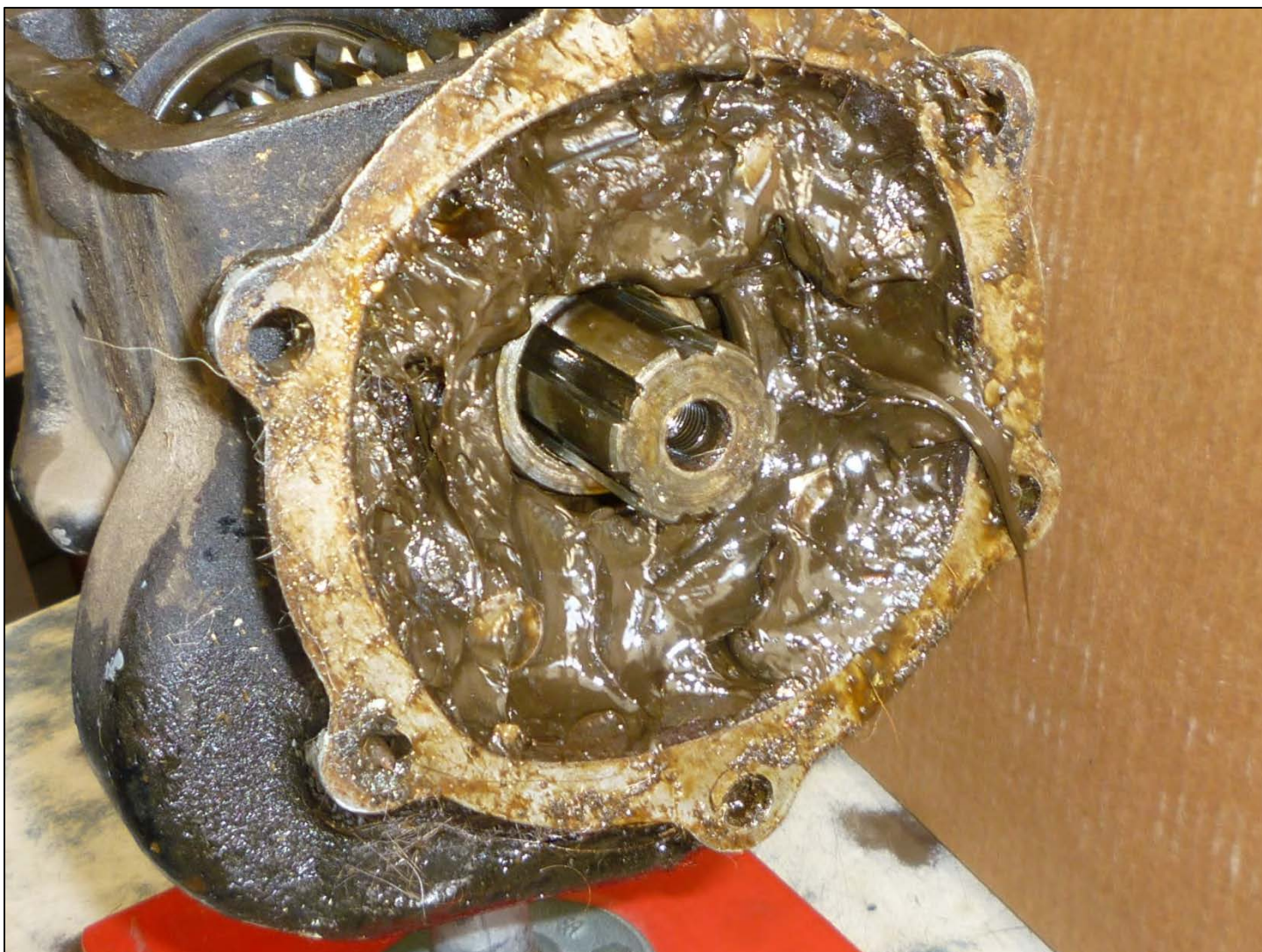

Shown here is the rear bearing retainer at the back of the transmission. The U-joint housing bolts up to the six bolt holes, and the U-joint slides onto the protruding splined shaft and bolts to it.

Buried under all the grease are four 5/8" hex bolts that are safety wired. The bolts hold the retainer to the back of the transmission housing.



Once the four bolts are removed the rear bearing retainer is removed by just pulling it off.

Directly below the rear bearing retainer mounting is a 9/16" hex bolt that holds the cross piece that retains the end of the cluster gear shaft and the reverse idler gear shaft; this bolt is also removed, along with the cross piece.



The rear bearing retainer and the four bolts are shown removed.



With the rear bearing retainer removed the main shaft can easily be pulled out to the rear by hand. The two slider gears will also come loose and both can be removed from inside the transmission.

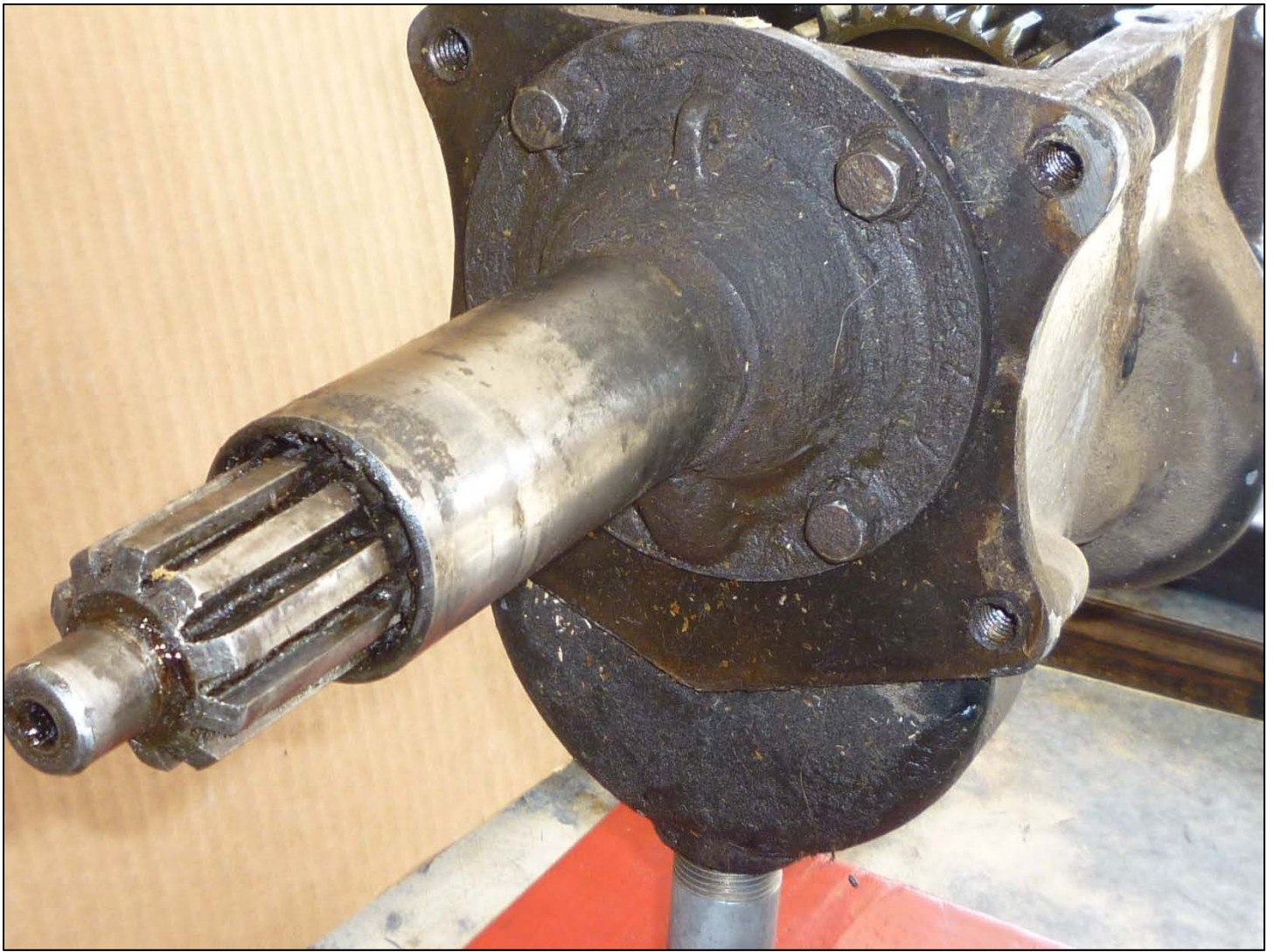

Shown here is the front bearing retainer with the splined input shaft protruding through it. The four 1/2" hex bolts will be removed.



With the front bearing retainer removed reach into input shaft where the gear is shown and with your fingers remove the roller bearing.

Using a long punch, insert it into the area where the roller bearing was removed and tap on it with a hammer to drive the input shaft out the front of the transmission.



Shown here is the removed front bearing retainer, the roller bearing, and the input shaft.



With a long punch place it against the cluster gear shaft at the back of the transmission and drive the shaft out the front.



With the cluster gear shaft removed reach in through the top of the transmission and grasp the cluster gear and lift it straight up and out. Inside the cluster gear should be two roller bearings (a short, and a long), and a spacer.

Shown here are the removed cluster gear, the cluster gear shaft, the two bearings, and the spacer.

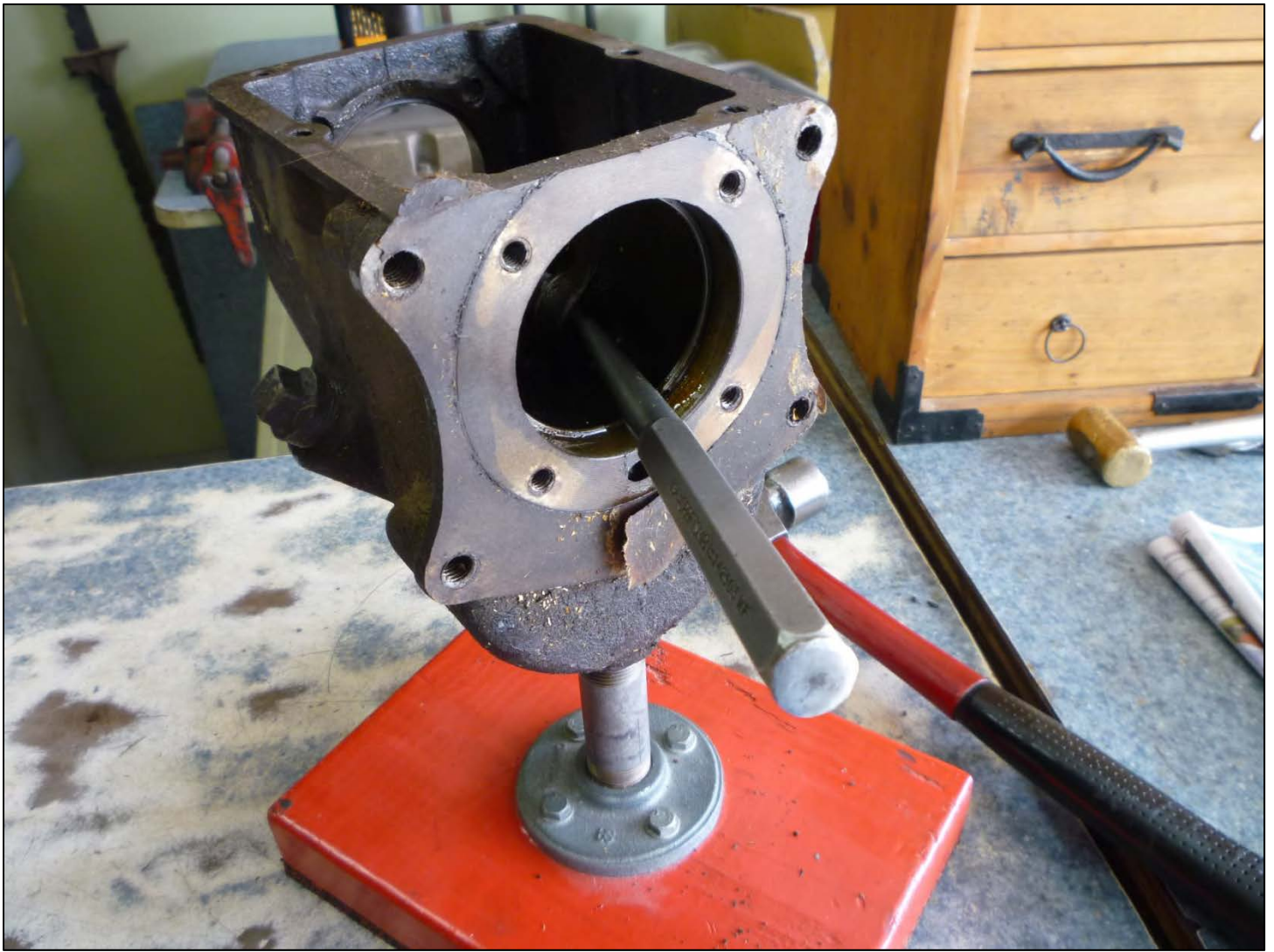

With a long punch insert it into the front of the transmission at an angle and place it against the shaft end of the reverse idler gear and tap it with a hammer. The shaft should easily come out the back of the transmission. The reverse idler gear can then be lifted out from inside the transmission.



Shown here is the removed reverse idler gear and the shaft.



Shown here are all the internal parts of the transmission that have been removed.



The cause of the profuse oil leak is found to be a gigantic crack that runs from the cluster gear shaft hole along the bottom of the transmission housing to the front.



The cause of the crack in the housing is a tooth broken off the cluster gear at the gear section for the low gear. The broken tooth migrated to the bottom of the housing and got under the reverse idler gear.



The culprit!!!

The tooth broken off the low gear on the cluster gear:



Shown here is the reverse idler gear with several damaged teeth. The damage to the housing was caused by the broken tooth off the cluster gear that got in between the reverse idler gear and the bottom of the case and caused the housing to crack.

This failure was more than likely caused by the driver trying to put the car in low gear while it was still traveling.

The instructions say to have the car at a full stop before attempting to shift into low or reverse.

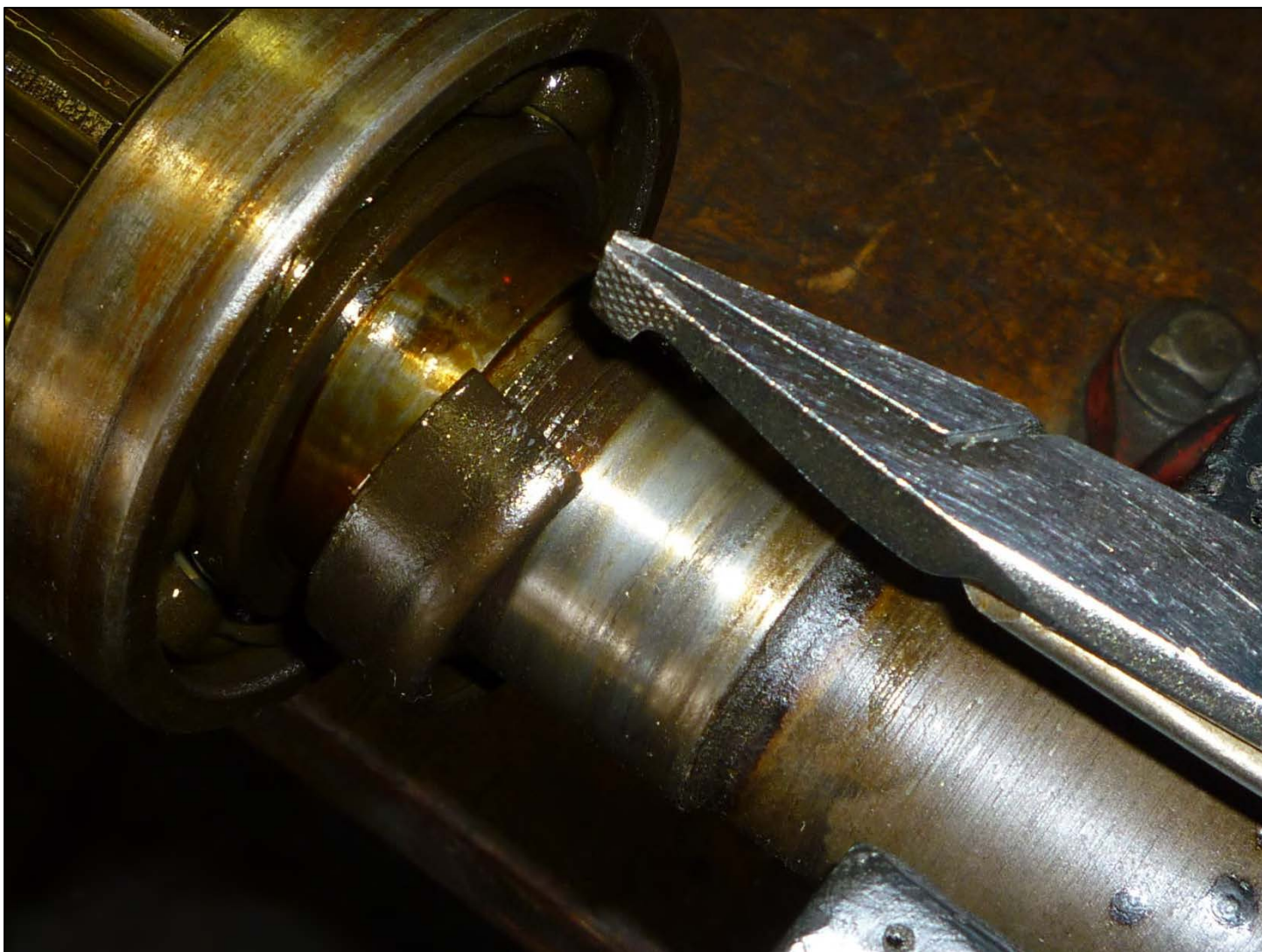

Shown here is a small retainer that secures the front ball bearing on the input shaft. It is C-shaped and was not one of Henry's better ideas. A pair of snap ring pliers are used to remove it, and sometimes that does not work. Most mechanics of yesteryear pried then off with a screwdriver and rendered them distorted and not suitable for reuse.

An early era modification that came into being is a sleeve and a snap ring. This is what will be used when the assembly process begins.



Shown here is a pair of snap ring pliers and Henry's not so better idea C-shaped bearing retainer removed from the input shaft.

The cross section of the retainer spans the space on front of the bearing on the input shaft and the ridge at the top is supposed to snap into the groove on the shaft. If the retainer is distorted it can easily come loose and allow the retainer and the front bearing to migrate forward.



Shown here is the front ball bearing being pressed off of the input shaft after the C-shaped retainer was removed. A shop press is needed to do this task as the bearing is usually pressed on tight.



Shown here is the input shaft and the front ball bearing after it was pressed off the shaft. Also shown is the front bearing oil baffle that installs between the bearing and the gear end of the shaft.



Shown here is the rear ball bearing on the main shaft being pressed off using a shop press.

The rear ball bearing is not pressed onto the main shaft tightly. Often a shop press is not needed as the bearing will slide off the shaft with little effort.



Shown here is the main shaft with the rear ball bearing removed. Also shown is the oil baffle that installs between the bearing and the bearing stop on the right end of the main shaft.

Also shown here is the pilot bearing spacer that installs on the left end of the main shaft up against the spline. It is easily pried off the shaft with a screwdriver. It is always prudent to replace this spacer during an overhaul as the front side is usually worn flat from riding against the rotating pilot bearing.



Shown here are the 100% replaceable parts removed from the transmission that will be replaced.

At the top of the photo are the three roller bearings. Next are the two ball bearings. Below that is the pilot bearing spacer and the revers idler gear shaft.

At the bottom are the C-shaped front ball bearing retainer and the cluster gear shaft.

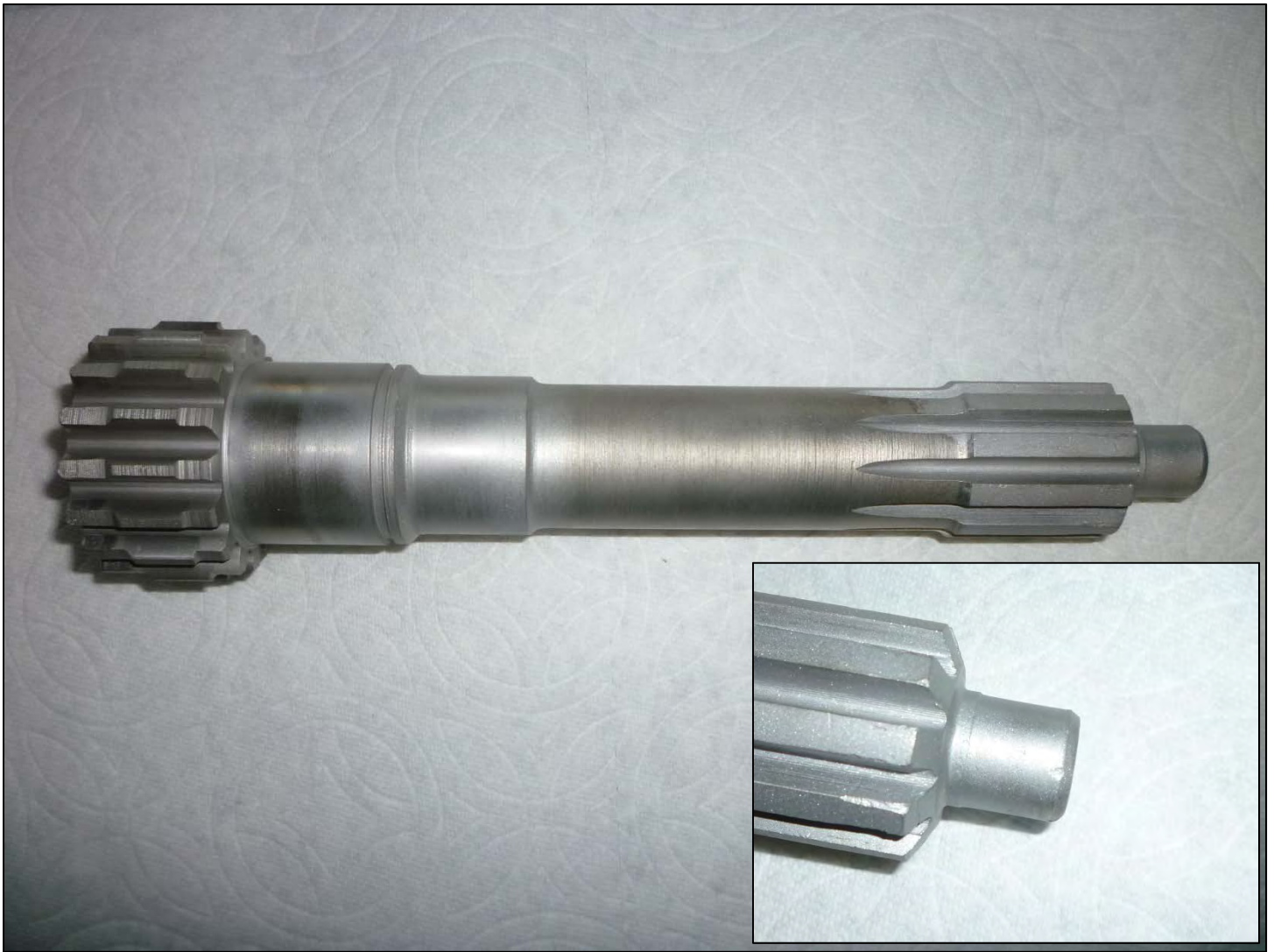

Shown here is the input shaft after it was de-greased and bead blasted. There are four things to be checked to determine if the shaft is serviceable: First is the condition of the gear on the left end of the shaft, and it is in excellent condition. Next is the spline on the right end of the shaft and it also is in excellent condition. The third thing to check is the nose on the right end of the shaft. This nose fits inside a bearing in the center of the flywheel. Often the nose is found worn and grooved and reduced in diameter such as this one is. See the inset photo. This situation however, is repairable. Jim's Automotive Services in Costa Mesa, California has a repair where he machines the nose down and presses on a hardened drill bushing that will return the shaft to a serviceable condition. The fourth thing to check is the bearing race surface inside the gear end of the shaft where a roller bearing rides. The surface should feel smooth as you run your finger around the inside diameter. Often it is found to be pitted or found to have indentations in the surface from a roller bearing sitting static inside for many years. The surface will have "ripple" feel to it. That is the case with this shaft. The ripples are definitely there and it is a second reason to reject this shaft and replace it with one that is serviceable.

The shaft can still be used as an alignment tool when installing a new clutch.

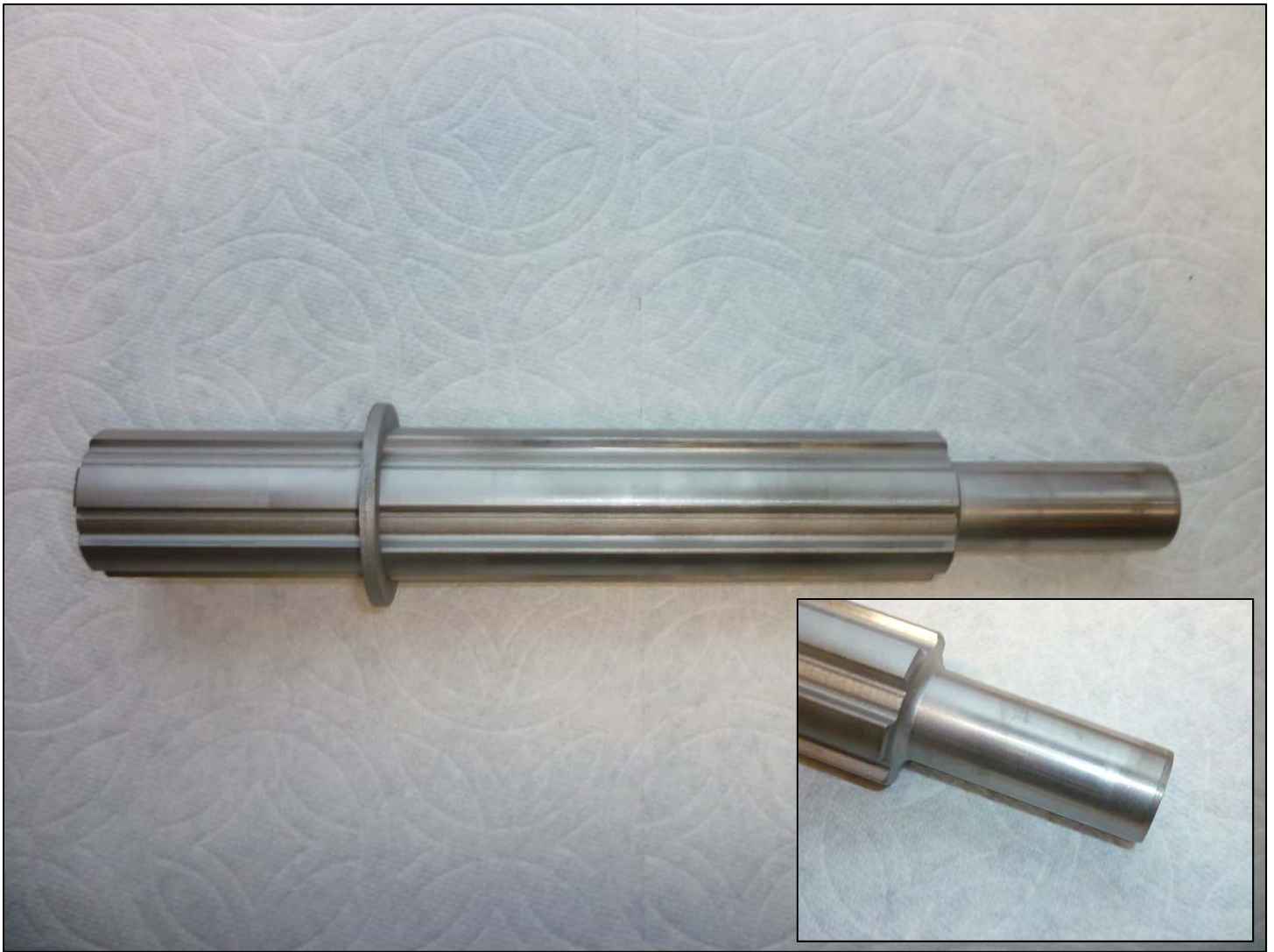

Shown here is the main shaft after it was degreased and bead blasted. The right end of the shaft is a bearing surface where the input roller bearing rides and it should be free of any pits that would indicate the case hardening is wearing off. If there is the slightest indication of wear the shaft should be rejected. This shaft is in excellent condition as seen in the inset photo. A new pilot bearing spacer will be installed on this end of the shaft and seated against the spline.

There is a repair for a main shaft that has a damaged roller bearing surface. See the next page for an article that was inserted into this document about the repair process.

Transmission Mainshaft Repair

The Mainshaft in the Model A Ford transmission is the shaft the two slider gears slide back and forth on. At the very front of the shaft is a bearing surface to support the small roller bearing that rides on it. Quite often the bearing surface is found worn and galled. In this case it should be replaced or repaired.

The repair is done by turning down the bearing surface and pressing on two bearing races of the proper size. This will restore the bearing surface and is a lot less costly than a replacement reproduction shaft that may be of questionable quality.

From a bearing supplier obtain two ER081212 Thornington Bearing races. The races have an **inside diameter of .500 - .4996**. The **outside diameter is .7493 - .7488**. This will accommodate the standard Model A roller bearing.

Turn the mainshaft bearing surface down to .5005. Stay approximately 1/8" away from the curved shoulder on the latter shafts that use the removable circular thrust washer. Don't machine it square at the shoulder, leave a small radius. For the early shafts with the integral thrust washer machine up to the washer surface.

Press the two bearing races onto either machined shaft. They should go on with an interference press fit. A small area of the machined shaft will protrude from the end, but this is not a problem as the positioning of the two bearing races will support the roller bearing properly.

This information was first published in the July/August 1985 publication of the Restorer on page 13, in an article written by Harold Powers of Scotia, California.

This service can be provided by:
Jim's Automotive Services
Costa Mesa, California
714-546-2969
Owner: Jim Nichols



The two main shafts on the lefts are of the early design that has a thrust washer as an integral part of the shaft. The shaft on the left is an early shaft shown in its original configuration. The one to the right of it is an early shaft that has been machined and has two of the Thornington bearing races pressed onto it.

The two main shafts on the right are of the later design that uses a removable thrust washer that is circular and is shaped much like a key ring. The shaft on the left is shown in its original configuration. The one on the right is a later shaft that has been machined and has two Thornington bearing races pressed on.

On the later shafts care must be taken when doing the machining so that the radius for the removable thrust washer is left intact.

Whenever rebuilding a Model A transmission it is prudent to always replace the removable thrust washer on the later design main shafts as they are generally found worn flat on the front surface.

It is also prudent to replace all five bearings in the transmission when doing a rebuild. The early and late main shafts are interchangeable in either the early or late transmission.



A new pilot bearing spacer is installed on the bearing end of the main shaft; this is easily accomplished by tapping it on using a 3\4" deep socket. Coat the shaft bearing surface with Vaseline first to aid sliding it into place without damaging the bearing surface. The inset photo shows the spacer being tapped into place. What appears to be markings on the bearing surface is a disruption of the Vaseline coating.

The early main shafts have a flat washer that is integral to the shaft that is the pilot bearing spacer and it is not removable. If you are installing an early main shaft don't make the mistake, as some have done, of installing the replaceable pilot bearings spacer on top of the integral one, as you will jam up the transmission.

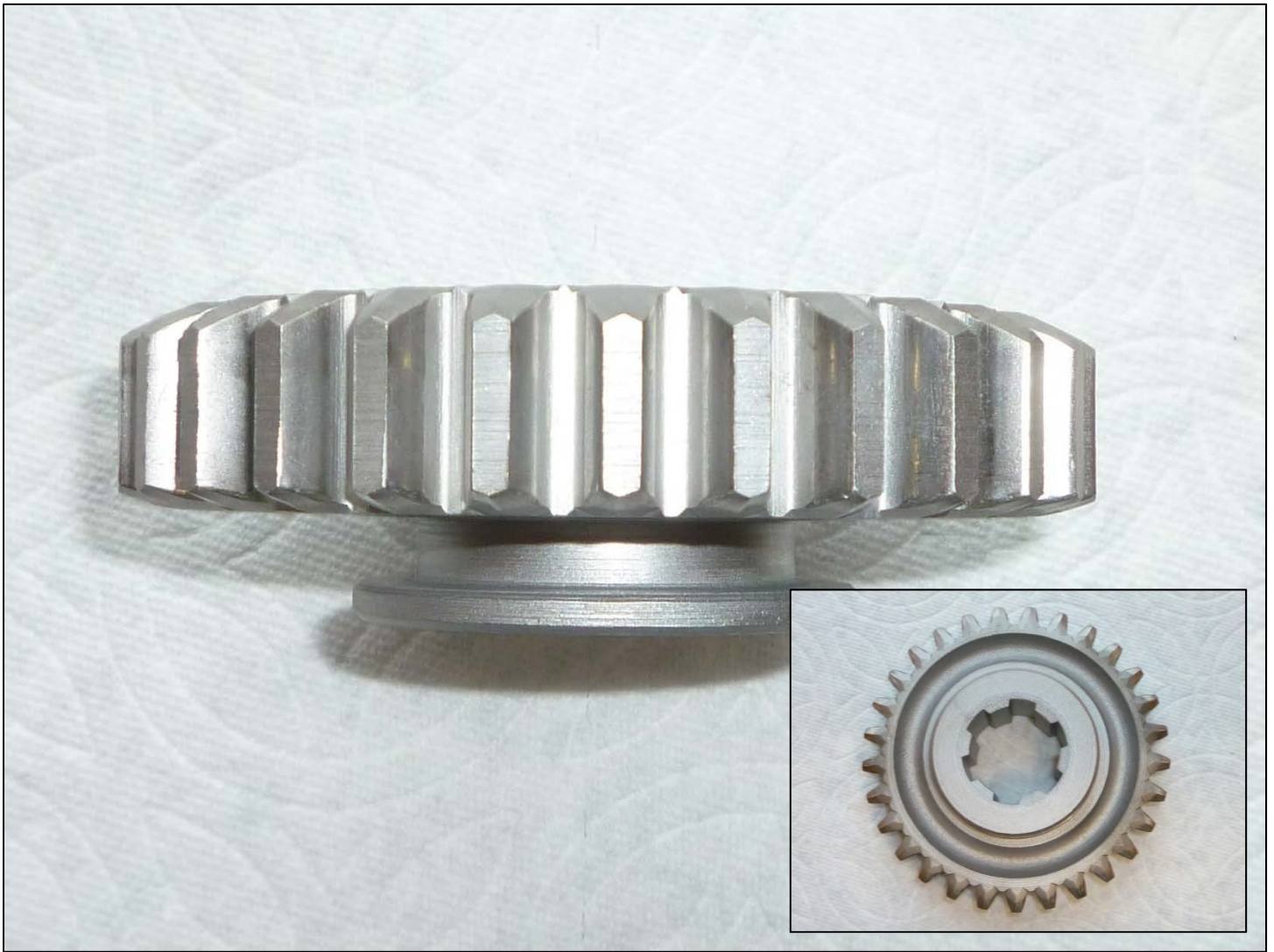

Shown here is the rear slider gear after it was degreased and bead blasted. This gear is used for both low gear and reverse gear. It is important that all the teeth are in good condition with no broken, chipped, or eroded teeth. The gear is in excellent condition and will be reused. Note the lower side of the gear is the location of the shifting fork slot.

The inset photo shows the flat side.

The rear slider gear is the larger of the two slider gears.



Shown here is the front slider gear after it was degreased and bead blasted. This gear is used for both second gear and high gear. It is important that all the teeth are in good condition with no broken, chipped, or eroded teeth. The inset photo shows the gear teeth. Note the shifting fork slot is located on the right side of the gear.

The series of holes on the front side of the gear is where it engages the back side of the gear on the input shaft. This is the design for the high gear. When the two gears are engaged the rotation of the engine is driving straight through the transmission and no “gearing” is going on. The output shaft is then rotating at the same speed as the input shaft.

The series of holes should not appear to be wallowed or otherwise distorted or it can cause the transmission to slip out of high gear.

This gear appears to be in excellent condition.

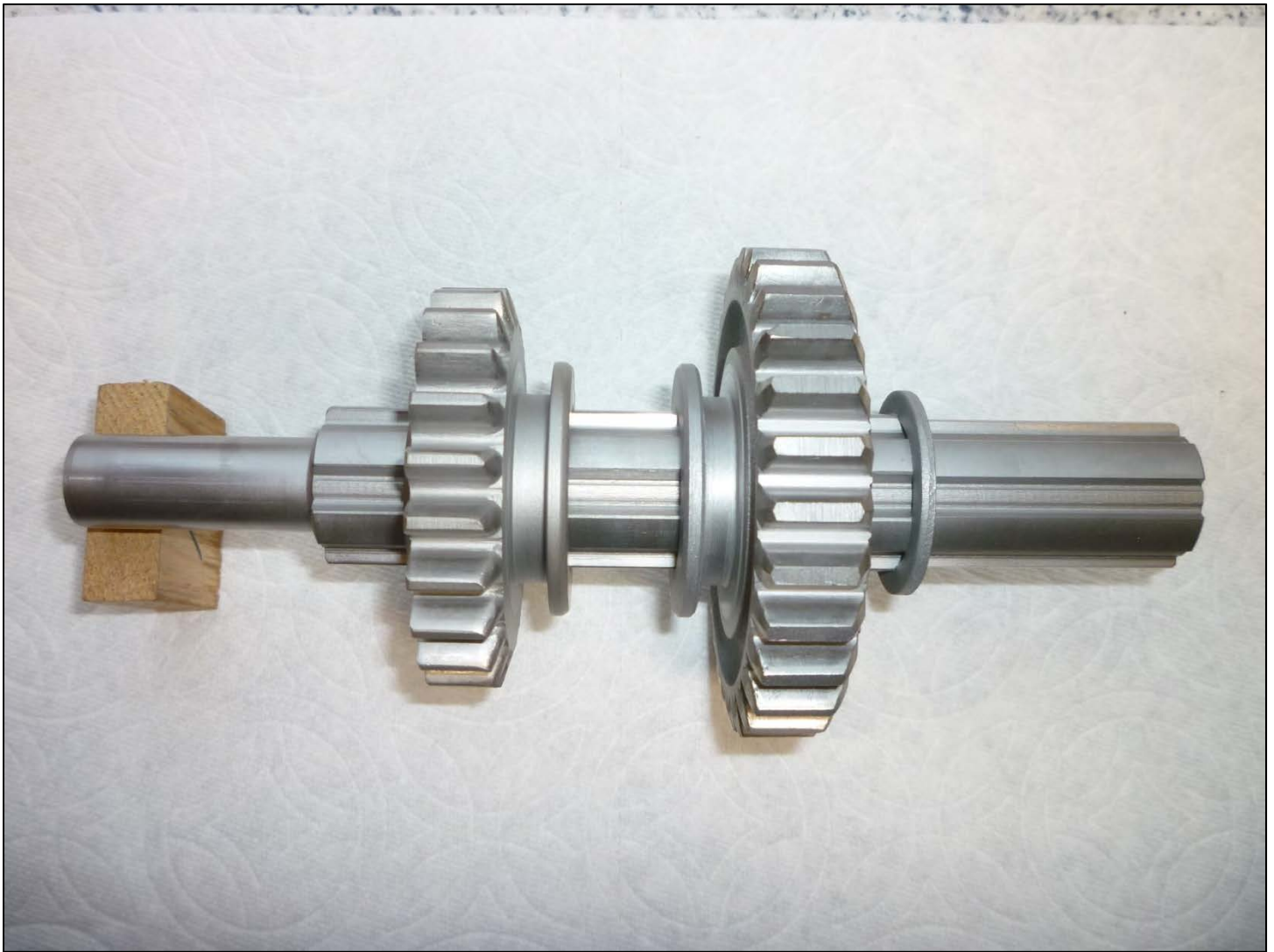

Shown here are the two slider gears mounted on the main shaft. It is important that the gears slide on the main shaft with a reasonable snugness. And this assembly does.

Ford issued a service bulletin back in the era describing the need for the snugness. The bulletin decreed that when replacing any one of the three parts, they should all be replaced as a matched set from A Ford dealer; the object being to minimize a transmission from jumping out of gear; an excellent way to increase parts sales then, but of no value today.

There are a number of reasons why a Model A will jump out of gear and this reason is way down on the list.

When assembling a transmission the snugness should be checked. If they are way loose, try to match them up with the use of other parts.



When mating up an input shaft with a main shaft that came from two different sources it is prudent to check that they are compatible with each other where the front roller bearing resides. It is possible that the end of the main shaft bearing surface area that extends past the roller bearing (see inset photo) may contact the bottom of the relief hole drilled inside the input shaft.

A way to check is to insert the main shaft into the input shaft with the bearing and pilot bearing spacer installed. Push them together with your hands and rotate them in opposite directions. They should turn smoothly with no binding. If it is questionable, coat the end of the main shaft with a marking pen and rotate the two parts to see if a witness mark is left on the end of the main shaft.

If there is binding, material can be ground off the end of the main shaft.



Shown here is the front bearing retainer after it was degreased and bead blasted. The sleeve portion on the right is where the throw-out bearing slides. It should be free of obvious gouges or grooves. This one is in excellent condition.

This part should not be painted. Make sure there is no paint or crud on the diameter on the left. This diameter fits very precisely into the rear of the bell housing, and if there is any obstruction it won't fit.

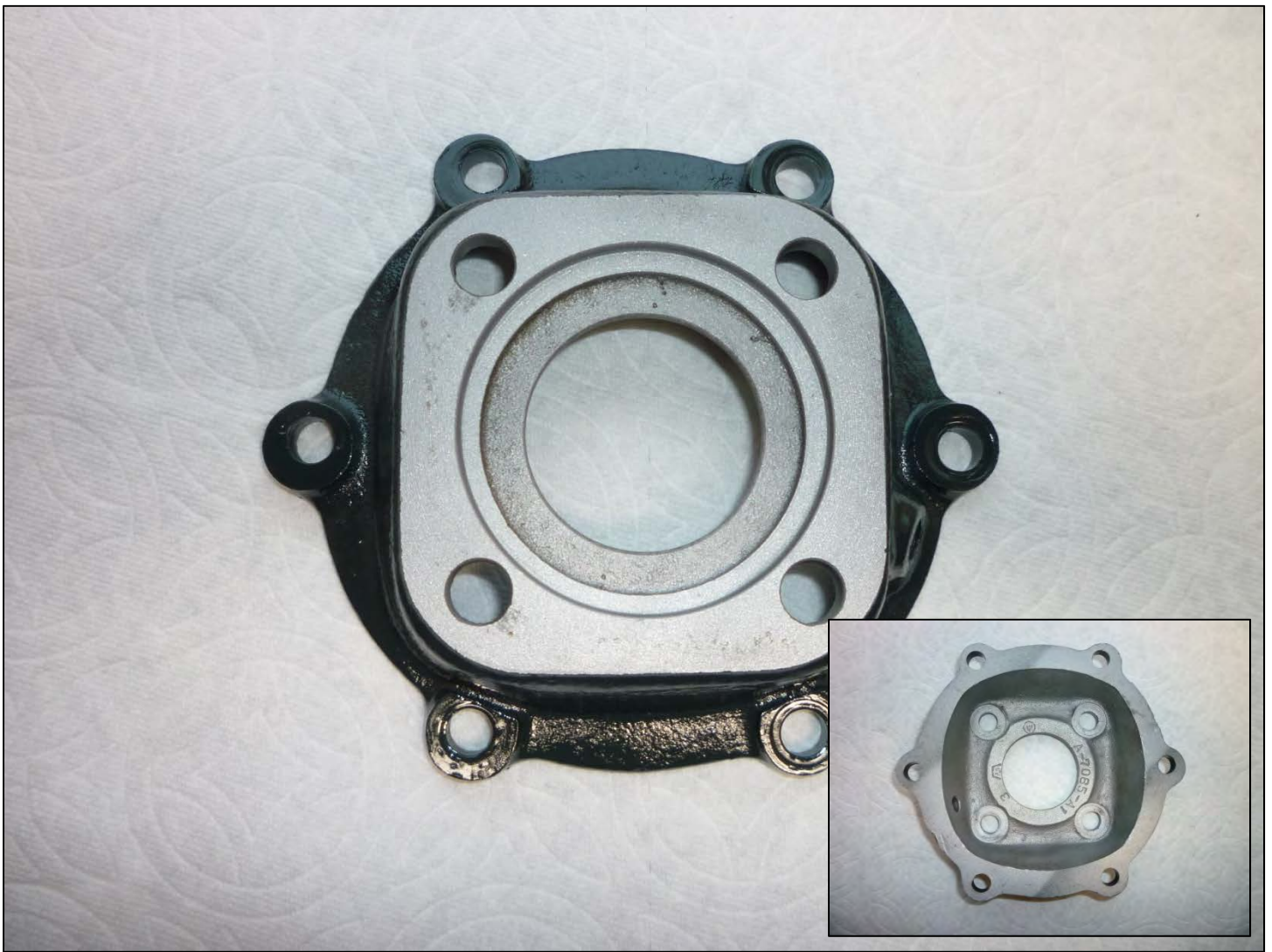

Shown here is the rear bearing retainer after it was degreased, bead blasted, and painted. The inset photo shows the back side. Check to make sure the four bolt holes that are used to mount it to the back of the transmission housing are not elongated. This can be caused by the mounting bolts being loose while the car was in service. This one is in good condition, and is the later version.

There were a number of variations of rear bearing retainers during the evolution of the transmission. However, there are only two variations that are of concern when rebuilding a transmission.

Ford made a change to the bolt pattern of the U-joint housing assembly that bolts to the six bolt holes on the rear bearing retainer sometime in 1929. The early U-joint housing bolt pattern is off-center. The later bolt pattern is symmetrical.

The date of the car the transmission is going to be installed in is not a factor. What is the deciding factor is what U-joints housing is being used on the car because they could have been changed a number of times during the life of the car. It is prudent to check before you install. All the rear bearing retainers will bolt up to the transmission housing. The two gaskets used are supplied with elongated holes to accommodate both types.



Shown here are all the rejected components that will have to be replaced before the transmission is assembled. These parts are in addition to the 100% replaceable parts.

Left to right: The transmission housing, the reverse idler gear, the cluster gear, and the input shaft.



The replacement components: The input shaft has had the nose repaired. It was machined down and a drill bushing sleeve pressed on. See inset photo. The reverse idler shaft and the cluster gear are originals in excellent condition.

The bushing inside the reverse idler gear is replaceable; however, it is not necessary as they are usually never worn. The idler gear only goes along for the ride, the only time there is any load on it is when in reverse.

There are those who advocate that you should not mate up used gears from different transmissions as they will be noisy. I don't agree with it. I have matched up many used gears with no problem. I believe the secret is to match gears that are in excellent condition. If you match up worn out gears, you probably will have noise.



The replacement transmission housing: It has been degreased, bead blasted, and painted. It is the later style with snap ring bearing stops as was the one it is replacing.



The miscellaneous parts have been degreased, bead blasted, and the threads of the bolts wire wheeled.

The next step is to assemble the transmission. To do that I need to find the three little guys.





The first task in the assembly process is to press the front ball bearing onto the input shaft and the rear ball bearing onto the main shaft. Before doing this it must be determined which housing you are using, early or late.

If you are using an early housing that have bearing stops that are integral to the housing you should use the early oil baffles shown here in the left column of the photo. If you are using a late housing that has snap rings for bearing stops you should use oil baffles shown in the right column of the photo.

You can get away with using early baffles in a late transmission housing as they will not cause a problem. However, if you use late oil baffles in an early transmission housing it will jam up the transmission.

When Ford made the change to the housing, they made the baffles slightly larger in order to compensate for the snap rings and provide proper oil control. There is a Ford service bulletin that describes the change.

Modern day Model A suppliers only sell the late baffles.

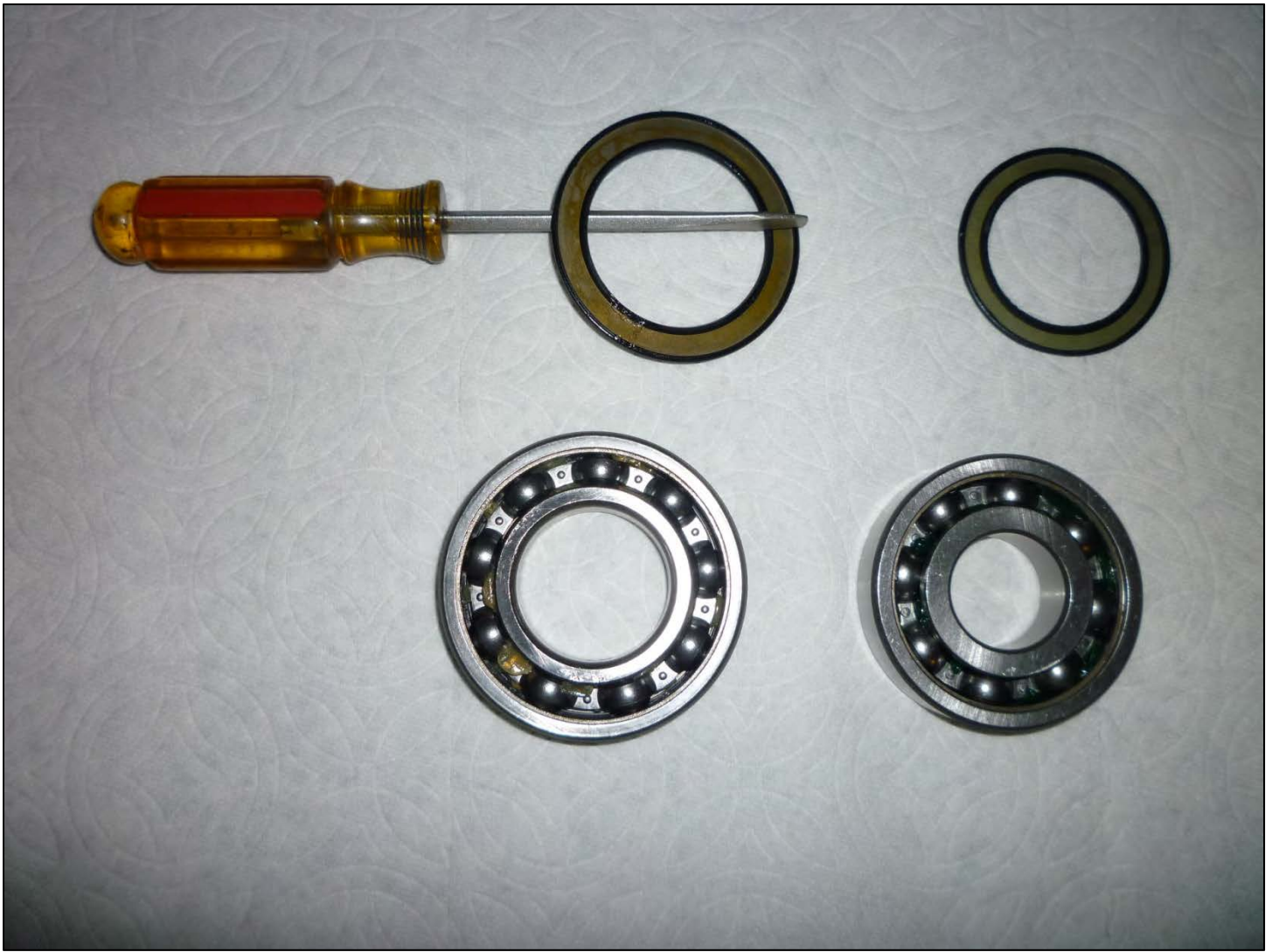

Shown here are the front and rear ball bearings; the front is on the left, the rear on the right. The new bearings to be installed are sealed on both sides. The seal is removed from one side of each bearing to allow oil to reach the bearing elements. The seal is easily pried off with a screwdriver. The bearings will install such that the side without the seal will face the inside of the transmission.



This is a close up of the rear bearing with the seal removed. Note there is very little grease applied by the manufacturer.

There are those who advocate that the seals should be retained on both sides, the theory being that it will keep out metallic wear particles that contaminate the oil.

I don't agree with this theory. I believe the bearing elements should receive continuous oil lubrication, and for that reason I always remove the seals from the inboard side of the bearings.



Shown here is the front ball bearing being pressed onto the input shaft. The oil baffle is put on first with the indent facing the bearing. The side of the bearing where the seal was removed is facing the oil baffle.



Shown here is the rear ball bearing being pressed onto the main shaft. The oil baffle has been put on first. The side of the bearing where the oil seal was removed is facing the baffle.



This photo shows the two bearings pressed onto both the input shaft and the main shaft. Note how there is about a 1\16” space between the oil baffle and the bearing. This is important; if the baffles had been put on backwards, as is often the case, the baffle would be jammed against the bearing and no oil would reach the bearing and metal would be continuously ground off the baffle as the bearing rotates.

If there is any distortion to the baffle that affects the spacing, slide a putty knife between the bearing and the baffle to straighten it out.

There are those that advocate that the oil baffles are not needed when sealed bearings are installed. The baffles should always be installed for dimensional reasons.

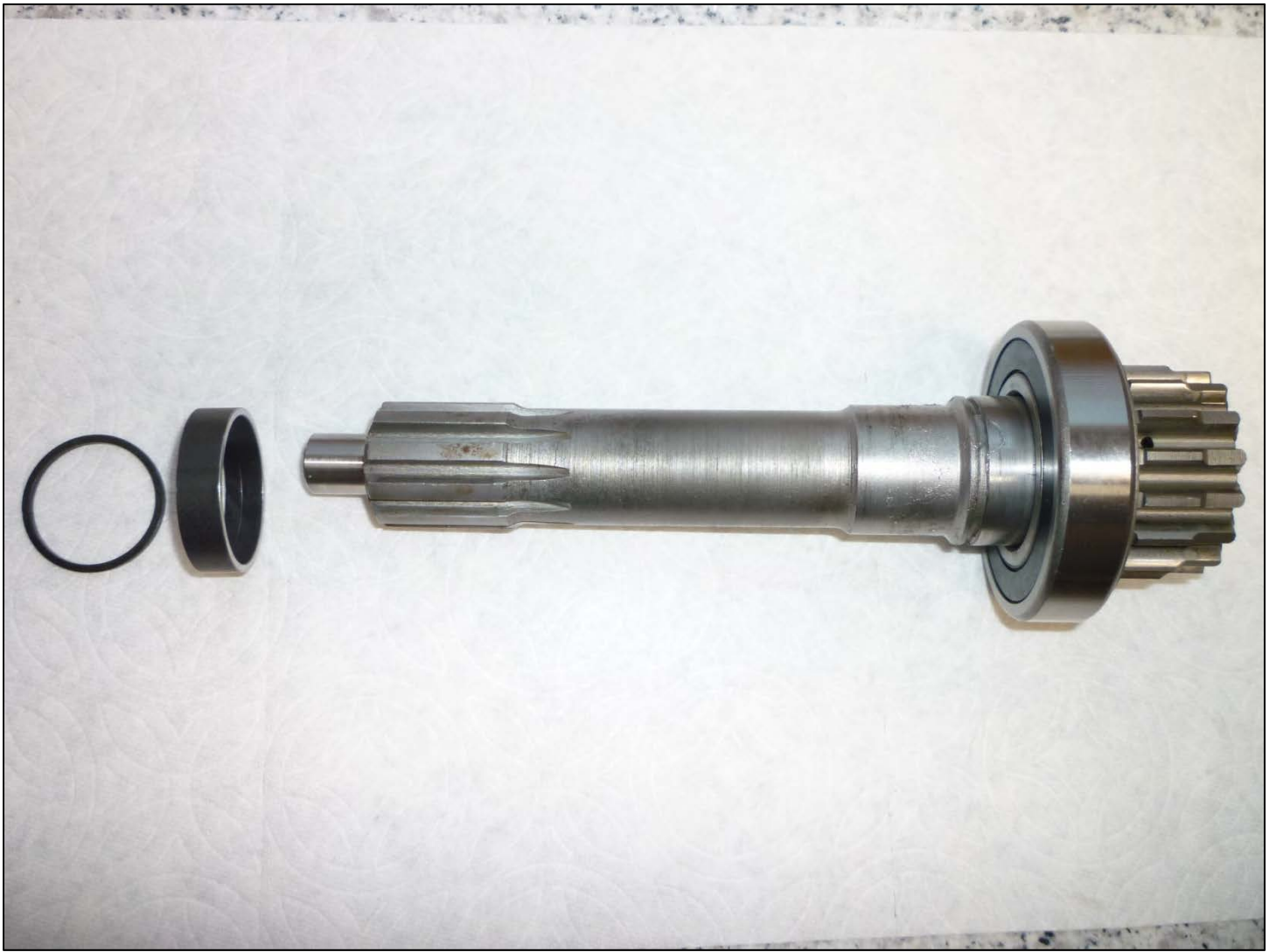

After the front bearing has been pressed onto the input shaft the sleeve and snap ring that replaces Henry's C-shaped bearing retainer is installed.



The sleeve and snap ring are slid onto the shaft and the shaft clamped in a vice. The snap ring is then worried into the groove in the shaft with a screwdriver.



Both the input shaft and the main shaft are now ready to install in the transmission. However, they are temporarily set aside while other components are installed in the transmission.



The transmission housing is set in a work stand. A snap ring is installed to the back and front since the housing is the late version.



The new replacement cluster shaft and reverse idler shaft both have been modified to provide O-ring seals to the rear of the transmission housing.

Model A Ford transmissions are notorious for leaking oil out the back of the transmission at both shafts. The O-ring mod will eliminate the leaks at the two shafts.

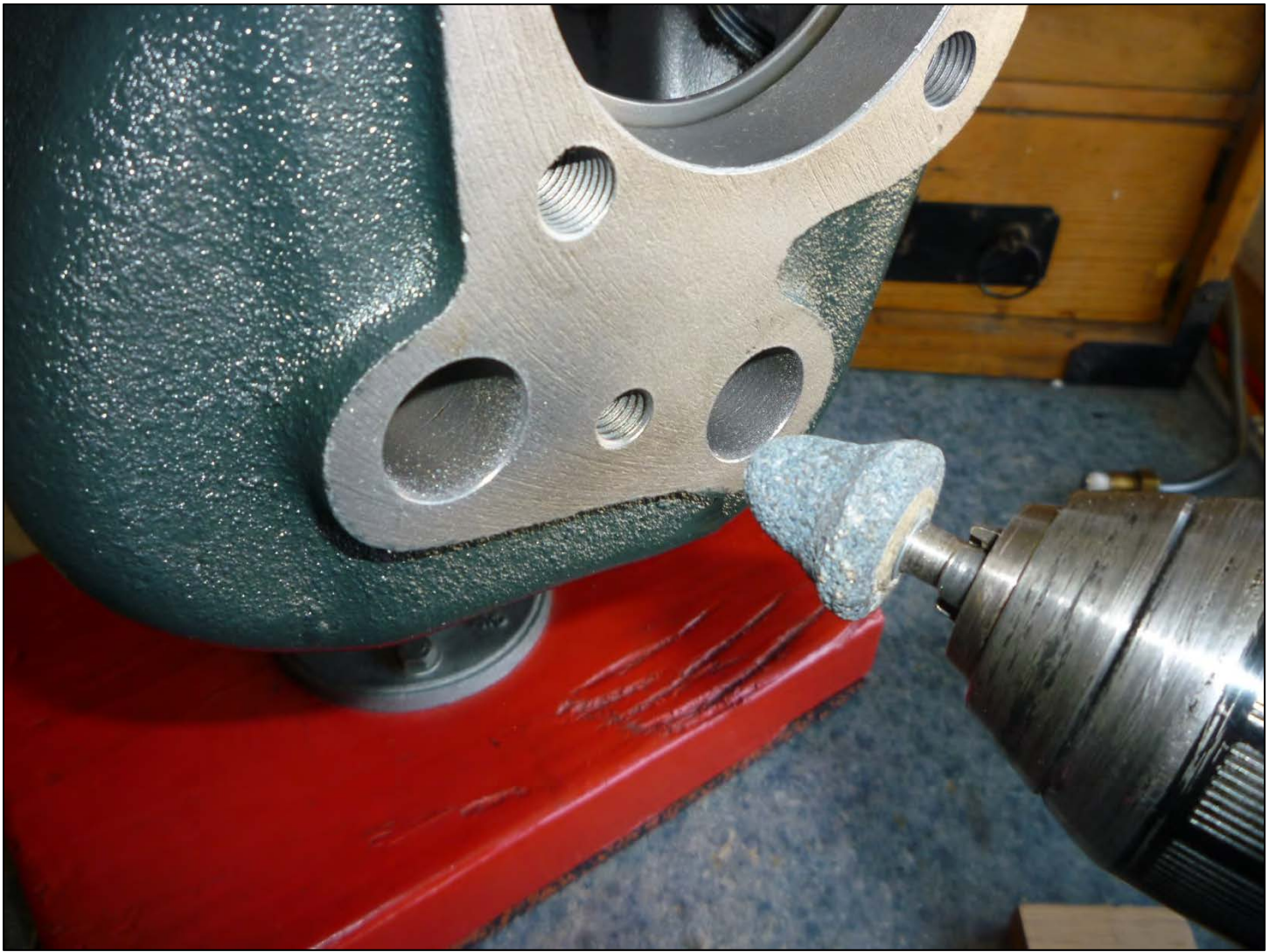

It is prudent to grind off the sharp edge on each shaft hole so as not to damage the O-rings when installed. Shown here is a drill motor with a tapered stone that does the job. It only takes a few rotations of the drill motor to taper the hole slightly.



Coat the reverse idler shaft and O-ring with Vaseline and slide it into the shaft hole part way. Place the reverse idler gear inside the transmission housing and slip it over the shaft.

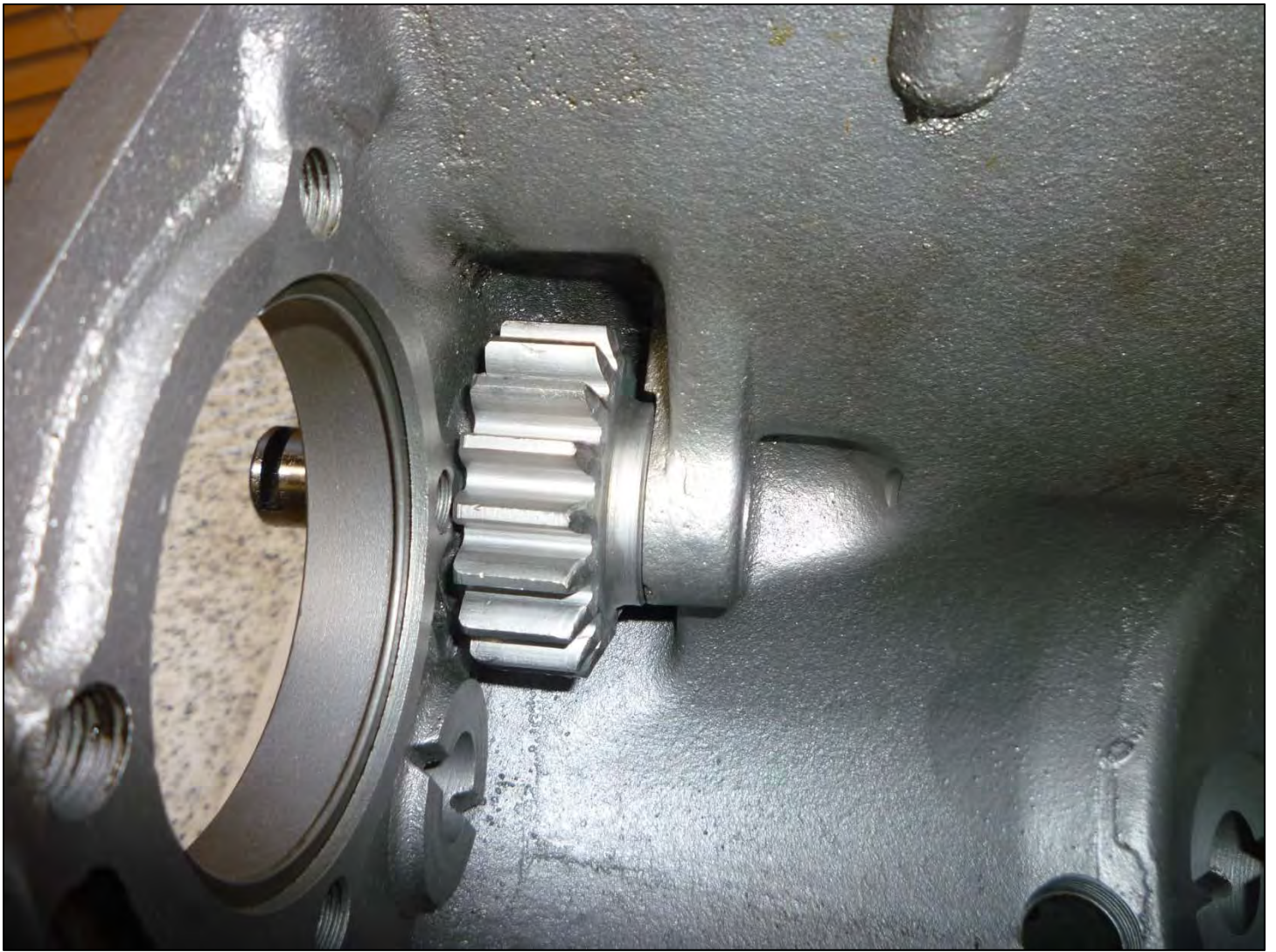

The reverse idler gear is positioned on the shaft so that the “snout” on the front of the gear faces forward in the transmission.



Shown here before further component installation are the three replacement roller bearings that will be installed in the transmission. These are good quality bearings from Bratton's Antique Auto.

Be aware that there are some very poor quality bearings being offered by several Model A suppliers. The bearings are so bad that they will certainly fail in a short time.

They are manufactures such that each roller element does not have a small axle on each end. They are constructed such that the element ends are rounded and fit inside a flimsy end cage that has mating dimples to capture the elements. The element will quickly wear through the end gages.



This is a close up of a roller bearing from Bratton's Antique Auto that shows how it is constructed. Each bearing element has a small axle at each end that fits through holes drilled into each end of substantial end cages.

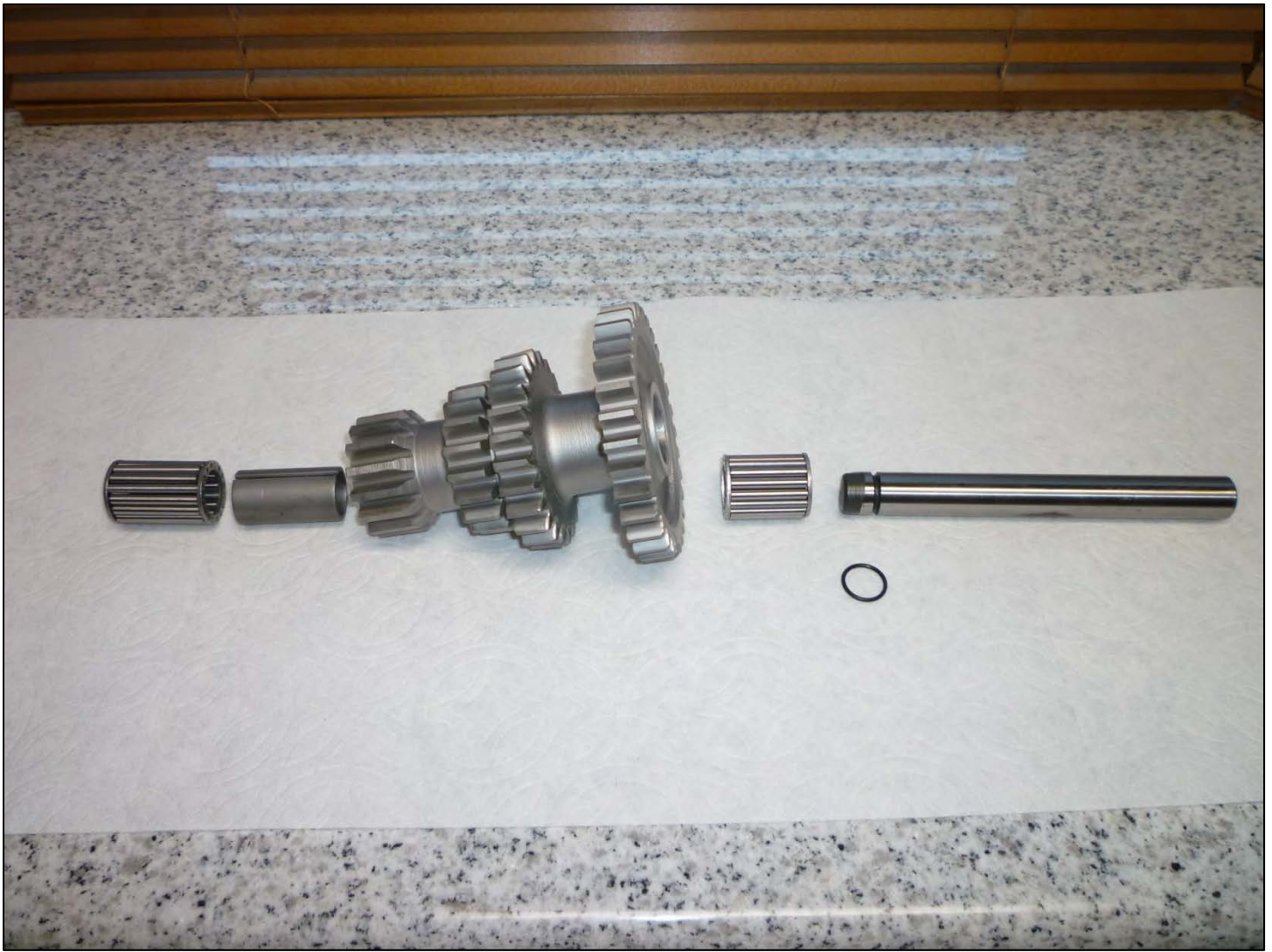

The cluster shaft assembly is installed next. This photo shows the orientation of the bearings and spacer that fit inside the cluster gear, Note that the longer of the two roller bearings goes in at the rear of the cluster gear (the smaller end).

The shaft must install from the front of the transmission housing as the shaft hole in the front of the case is .001 larger than the one at the rear. This was supposed to fit the shaft tight at the rear and control oil leakage. However, it didn't do a very good job.

Before installing the shaft, temporarily remove the O-ring from the shaft.

Apply oil to the two bearings before installing them inside the cluster gear along with the spacer.

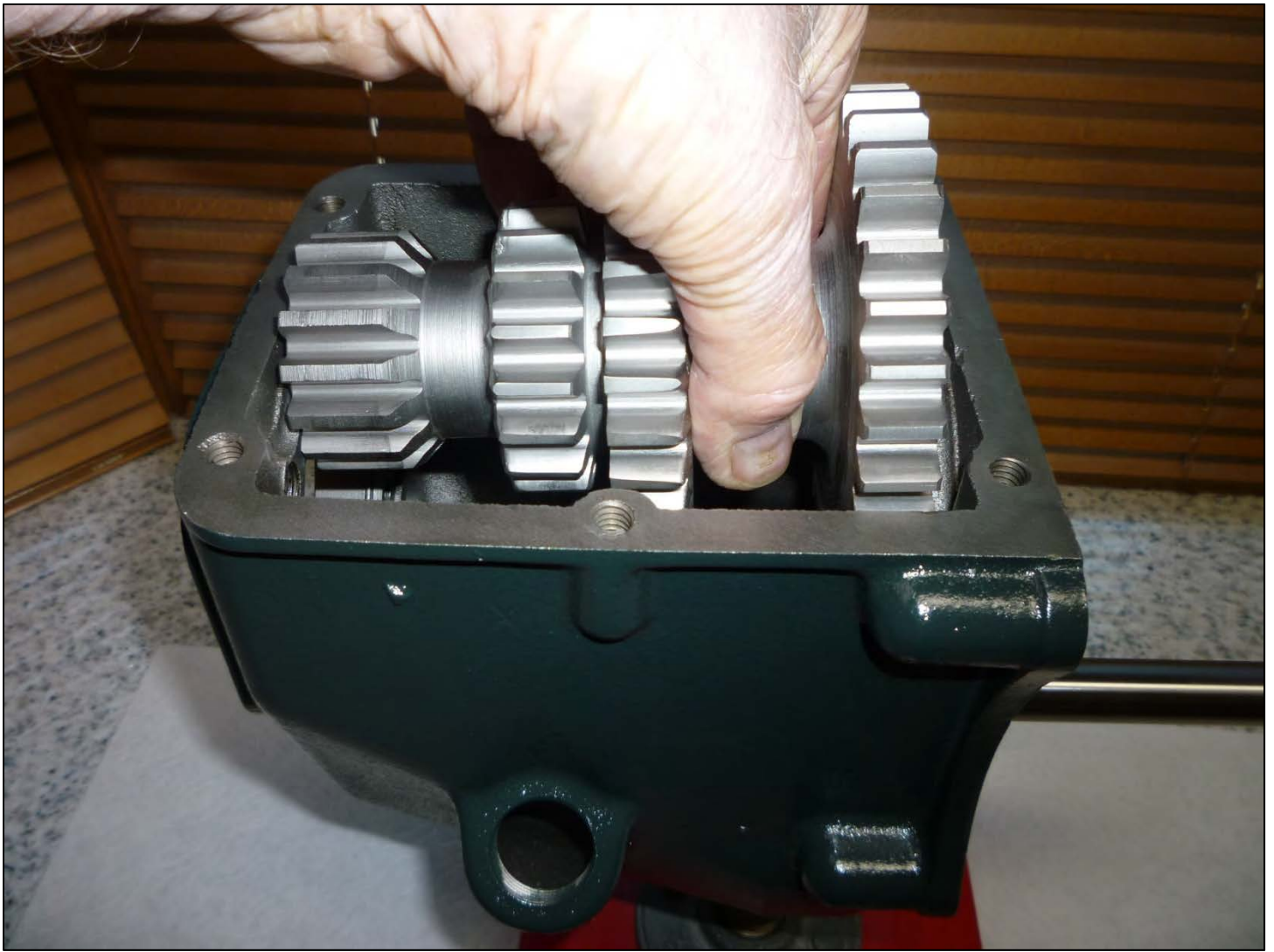

Hold the cluster gear assembly level while lowering it into the transmission housing. Then line up the cluster gear with the holes in the front and rear of the housing and slide the shaft into place.

Once in place move the cluster gear back and forth to determine how much thrust clearance there is. Various documentation calls out a number of acceptable values clear up to .020, depending on who is telling the story.

My experience has been that the acceptable thrust clearance should not accede .010.

This cluster gear has only a few thousands of clearance, which is more than acceptable.



Push the cluster shaft through the transmission case until it protrudes a small distance past the end so that the O-ring can be installed.

Tap the shaft back into place after the O-ring has been reinstalled.



Install the bolt and retainer to secure the two shafts and prevent them from rotation. Apply some sealer to the threads of the bolt to prevent transmission oil from migrating past the threads.

It is important that the correct length bolt be installed. The early shafts were retained with a 3/16 inch thick retainer. The length of the bolt used was one inch long. A change to the shaft requires a retainer that is only 1/16 inch thick. As a result the length of the bolt was reduced to 3/4 inch long. The photo shows the later configuration on the left, the early on the right. Suppliers only supply the later configure cluster shaft. This will require the use of the thinner 1/16 inch thick retaining. When overhauling a transmission you may find the early retainer. It is therefore prudent to locate a 3/4 inch bolt or cut a quarter inch off the original one inch bolt, as the longer bolt may constrict with the reverse idler gear.

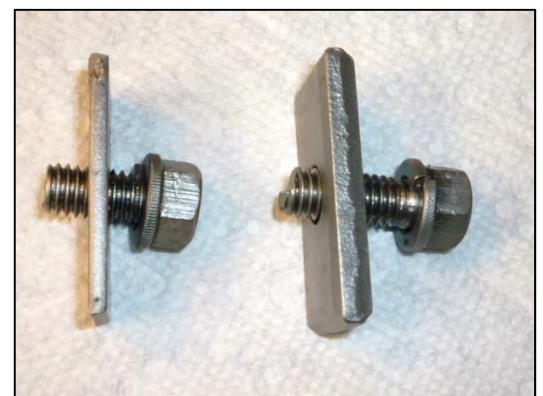

The next to be assembled is the main shaft and the two slider gears. First slip the main shaft through the rear of the transmission housing at an up angle. Slide the two idler gears onto the main shaft.

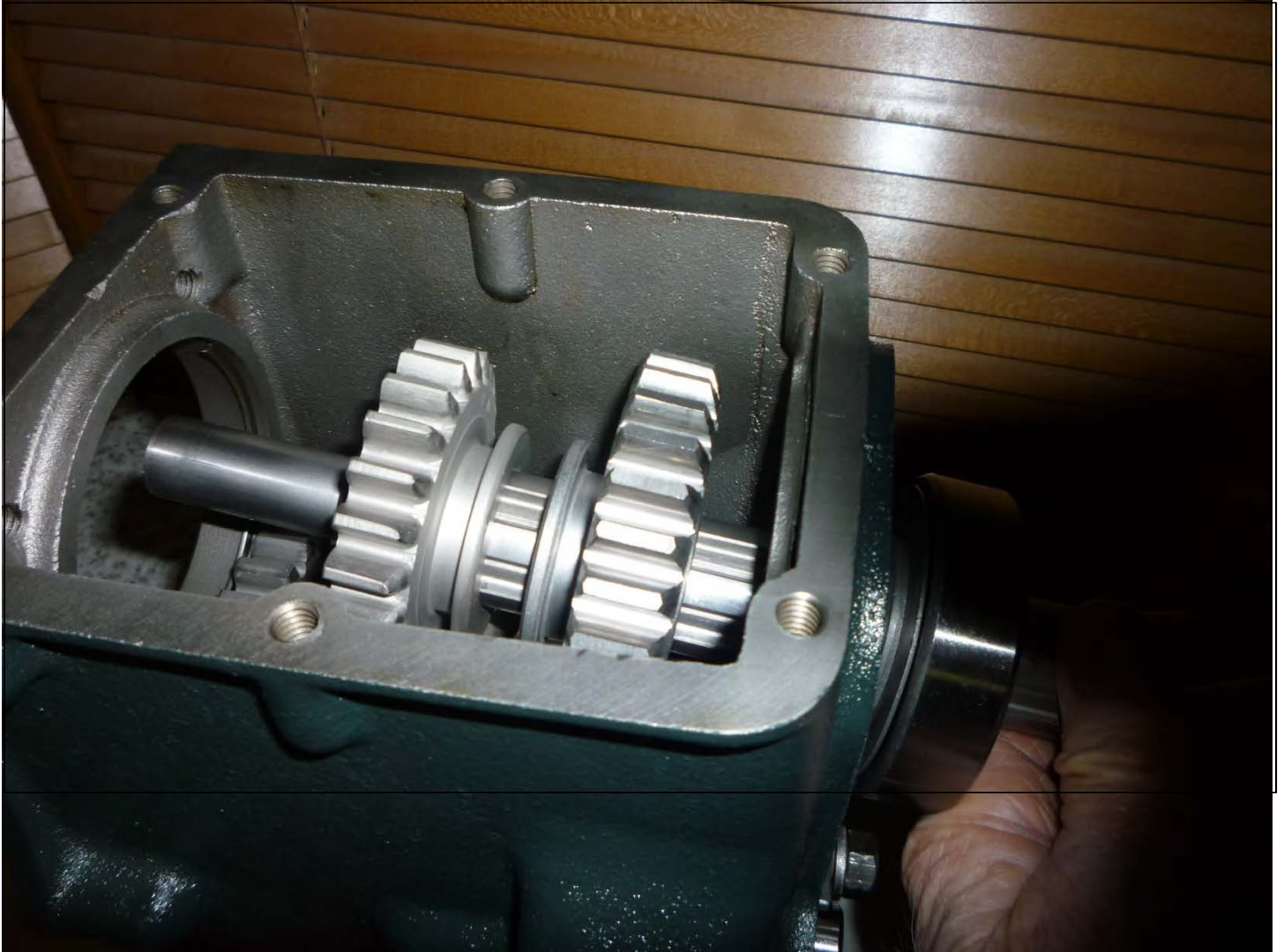

When sliding the two slider gears onto the main shaft, position them so the large slider is in the back, the front slider in front. The two slots on each gear for the shifting forks must face each other.



Shown here, the main shaft has been installed with the two slider gears riding on the spline of the shaft. Once the assembly is inside the housing push the rear bearing until it seats into the recess in the housing for the bearing and up against the snap ring.

With your fingers move the two slider gears to the neutral position as shown in the photo.



Put some oil on a short roller bearing and insert it into the gear end of the input shaft.

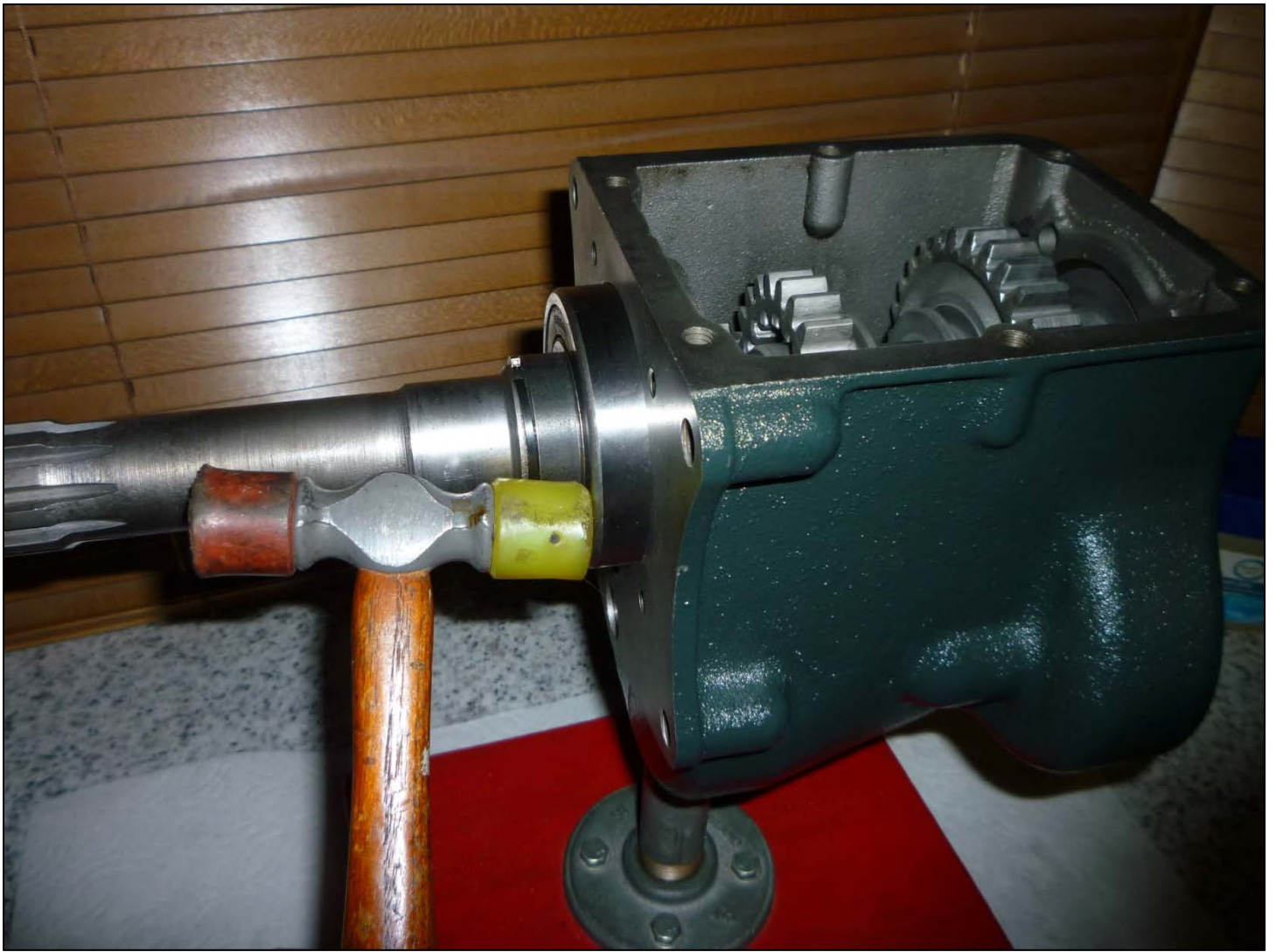

Slide the input shaft with the roller bearing inside into the front of the transmission housing. Guide it over the front of the main shaft and seat it into the front opening at the front of the transmission housing. With a soft hammer tap around the circumference of the bearing to get it started in the hole. The front bearing retainer can then be used as a puller-inner tool by evenly tightening the four mounting bolts until the bearing is seated up against the snap ring.

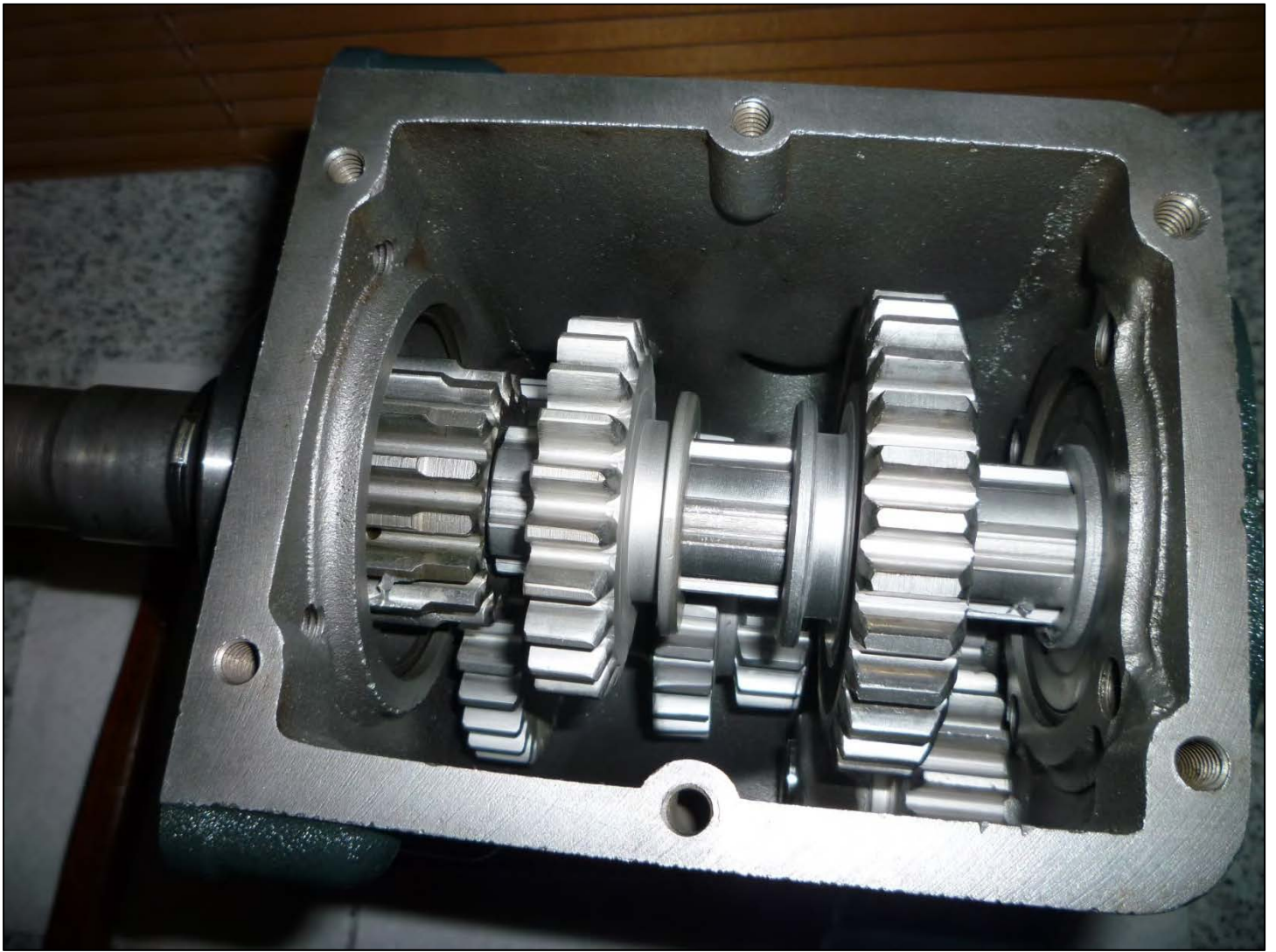

Shown here are all the internal components installed inside the transmission housing.

The next step is to install the front and rear bearing retainers.

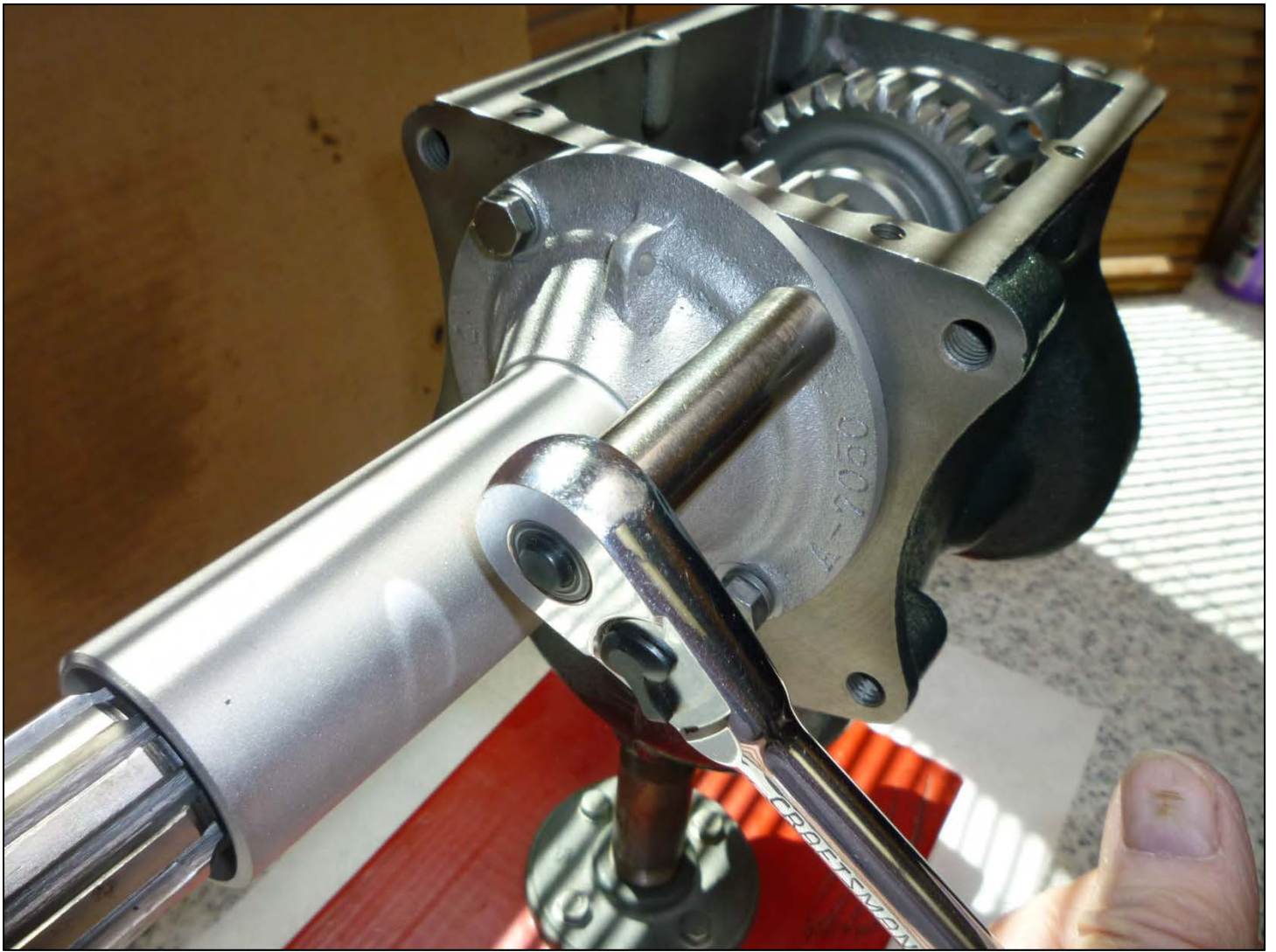

Install the front bearing retainer with a gasket coated on both sides with sealer. Coat the threads of the four 1/2" hex mounting bolts with sealer. The little "grabber" that the throw-out bearing slider assembly spring attaches to should be at the top as shown.

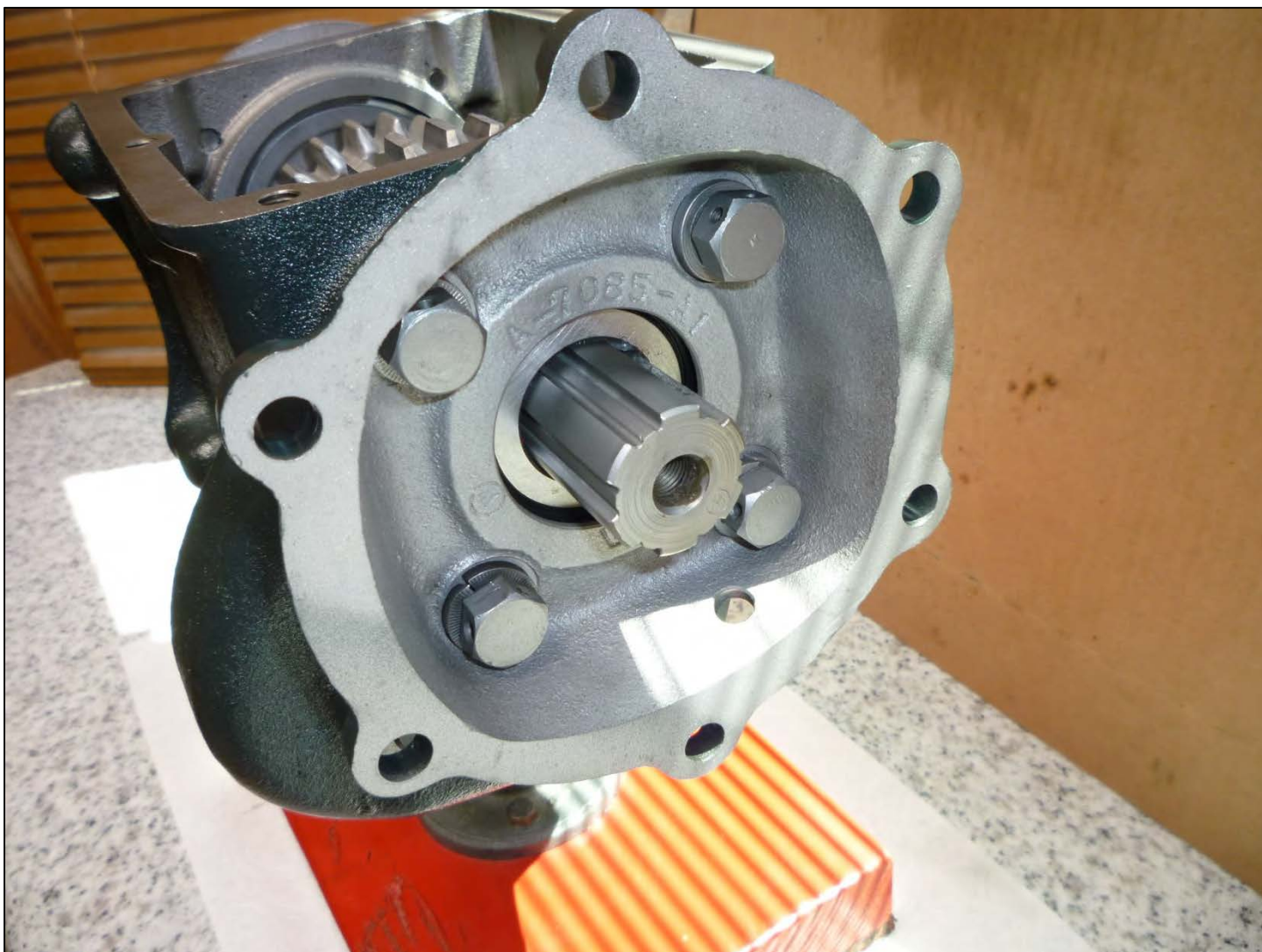

The rear bearing retainer with a gasket would normally be coated on both sides with sealer as well as the threads of the four 5/8" hex mounting bolts before installation. The four mounting bolts would be torqued to 45 ft. lbs. and safety wired.

However, since this transmission is not designated for installation in a particular car, there is no determination which (early or late) rear bearing retainer will be required. For this reason the four mounting bolts will be left loose, and no sealer will be applied to the gasket.

The rear bearing retainer shown installed here is the late version. An early version rear bearing retainer will be supplied with the transmission to whoever acquires it.

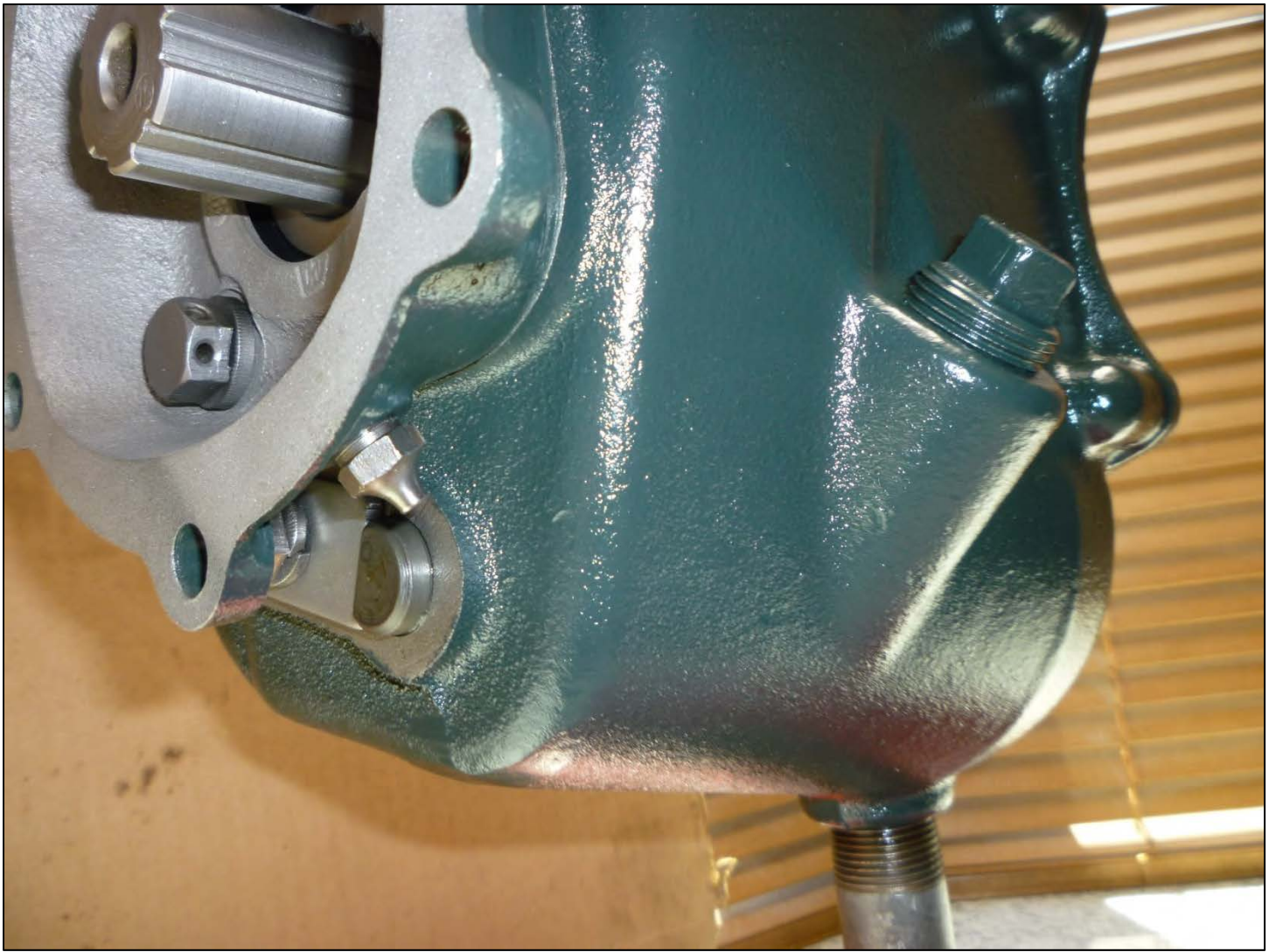

The rear bearing retainer when installed must be oriented so that the grease fitting is positioned on the lower right side as shown in the photo. It should be on the same side as the fill port.

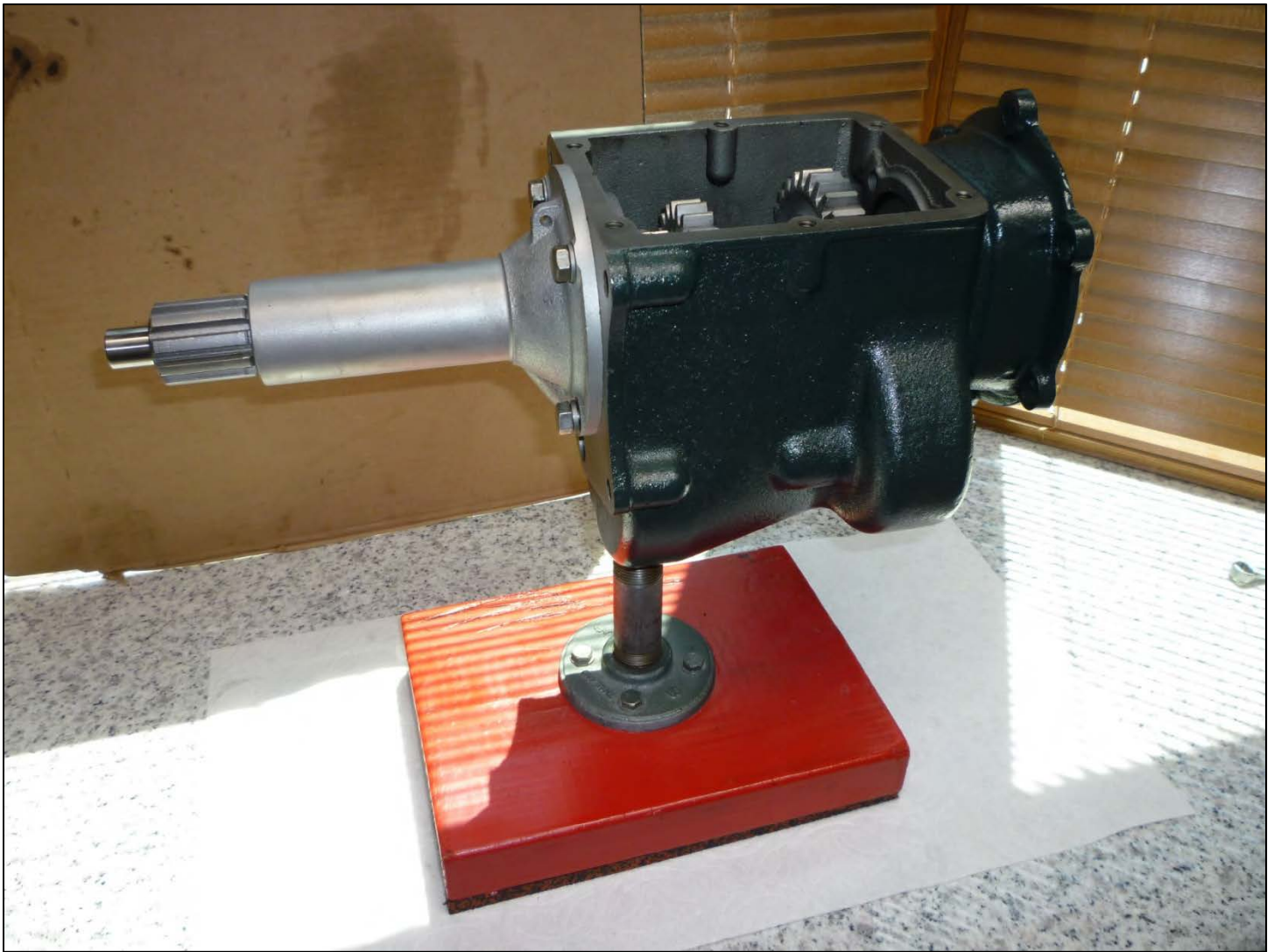

The finished product!

When complete it is prudent to rotate both the input shaft and the output shaft by hand, they should turn freely with no binding. With your fingers manually shift the transmission into each of the four gears and rotate the input shaft and observe the action. The transmission should manually shift freely.